

Instructions



TLA7KUP Logic Analyzer Field Upgrade Kit 071-1749-00

This document applies to TLA System Software version 5.1.

Warning

These servicing instructions are for use by qualified personnel only. To avoid personal injury, do not perform any servicing unless you are qualified to do so. Refer to all safety summaries prior to performing service.

www.tektronix.com

Copyright © Tektronix, Inc. All rights reserved. Licensed software products are owned by Tektronix or its subsidiaries or suppliers, and are protected by national copyright laws and international treaty provisions.

Tektronix products are covered by U.S. and foreign patents, issued and pending. Information in this publication supercedes that in all previously published material. Specifications and price change privileges reserved.

TEKTRONIX and TEK are registered trademarks of Tektronix, Inc.

Contacting Tektronix

Tektronix, Inc.
14200 SW Karl Braun Drive
P.O. Box 500
Beaverton, OR 97077
USA

For product information, sales, service, and technical support:

- In North America, call 1-800-833-9200.
- Worldwide, visit www.tektronix.com to find contacts in your area.

Warranty 6

Tektronix warrants that the parts and modules (“parts”) that it manufactures and sells will be free from defects in materials and workmanship for a period of three (3) months from the date of shipment. If any such part proves defective during this warranty period, Tektronix, at its option, either will repair the defective part without charge, or will provide a replacement in exchange for the defective part. Parts and modules used by Tektronix for warranty work may be new or reconditioned to like new performance. All replaced parts and modules become the property of Tektronix.

In order to obtain service under this warranty, Customer must notify Tektronix of the defect before the expiration of the warranty period and make suitable arrangements for the performance of service. Customer shall be responsible for packaging and shipping the defective part to the service center designated by Tektronix, with shipping charges prepaid. Tektronix shall pay for the return of the part to Customer if the shipment is to a location within the country in which the Tektronix service center is located. Customer shall be responsible for paying all shipping charges, duties, taxes, and any other charges for parts returned to any other locations.

This warranty shall not apply to any defect, failure or damage caused by improper use or improper or inadequate maintenance and care. Tektronix shall not be obligated to furnish service under this warranty a) to repair damage resulting from attempts by personnel other than Tektronix representatives to install, repair or service the part; b) to repair damage resulting from improper use or connection to incompatible equipment; c) to repair any damage or malfunction caused by the use of non-Tektronix supplies; or d) to service a part that has been modified or integrated with other products or parts when the effect of such modification or integration increases the time or difficulty of servicing the part.

THIS WARRANTY IS GIVEN BY TEKTRONIX WITH RESPECT TO THE PART IN LIEU OF ANY OTHER WARRANTIES, EXPRESS OR IMPLIED. TEKTRONIX AND ITS VENDORS DISCLAIM ANY IMPLIED WARRANTIES OF MERCHANTABILITY OR FITNESS FOR A PARTICULAR PURPOSE. TEKTRONIX’ RESPONSIBILITY TO REPAIR OR REPLACE DEFECTIVE PARTS IS THE SOLE AND EXCLUSIVE REMEDY PROVIDED TO THE CUSTOMER FOR BREACH OF THIS WARRANTY. TEKTRONIX AND ITS VENDORS WILL NOT BE LIABLE FOR ANY INDIRECT, SPECIAL, INCIDENTAL, OR CONSEQUENTIAL DAMAGES IRRESPECTIVE OF WHETHER TEKTRONIX OR THE VENDOR HAS ADVANCE NOTICE OF THE POSSIBILITY OF SUCH DAMAGES.

Warranty 9(b)

Tektronix warrants that the media on which this software product is furnished and the encoding of the programs on the media will be free from defects in materials and workmanship for a period of three (3) months from the date of shipment. If any such medium or encoding proves defective during the warranty period, Tektronix will provide a replacement in exchange for the defective medium. Except as to the media on which this software product is furnished, this software product is provided "as is" without warranty of any kind, either express or implied. Tektronix does not warrant that the functions contained in this software product will meet Customer's requirements or that the operation of the programs will be uninterrupted or error-free.

In order to obtain service under this warranty, Customer must notify Tektronix of the defect before the expiration of the warranty period. If Tektronix is unable to provide a replacement that is free from defects in materials and workmanship within a reasonable time thereafter, Customer may terminate the license for this software product and return this software product and any associated materials for credit or refund.

THIS WARRANTY IS GIVEN BY TEKTRONIX WITH RESPECT TO THE PRODUCT IN LIEU OF ANY OTHER WARRANTIES, EXPRESS OR IMPLIED. TEKTRONIX AND ITS VENDORS DISCLAIM ANY IMPLIED WARRANTIES OF MERCHANTABILITY OR FITNESS FOR A PARTICULAR PURPOSE. TEKTRONIX' RESPONSIBILITY TO REPLACE DEFECTIVE MEDIA OR REFUND CUSTOMER'S PAYMENT IS THE SOLE AND EXCLUSIVE REMEDY PROVIDED TO THE CUSTOMER FOR BREACH OF THIS WARRANTY. TEKTRONIX AND ITS VENDORS WILL NOT BE LIABLE FOR ANY INDIRECT, SPECIAL, INCIDENTAL, OR CONSEQUENTIAL DAMAGES IRRESPECTIVE OF WHETHER TEKTRONIX OR THE VENDOR HAS ADVANCE NOTICE OF THE POSSIBILITY OF SUCH DAMAGES.

Table of Contents

General Safety Summary	v
Service Safety Summary	vii
Environmental Considerations	viii
Preface	ix
Products Eligible for TLA7KUP Upgrades	ix
Service and Upgrade Notes	xii
Adjustment and Certification Interval	xii
Service Offerings	xii

TLA7KUP Option 15

TLA7KUP Option 15: iView External Oscilloscope Cable	
Installation	1-1
Instruments	1-1
Minimum Tool and Equipment List	1-1
Parts List	1-1
Installation Prerequisite	1-1
Installation Instructions	1-1
Attach the Upgrade Kit Label to the Instrument	1-2

TLA7KUP Option 18

TLA7KUP Option 18: TLA7012 Touchscreen Installation	2-1
Instruments	2-1
Minimum Tool and Equipment List	2-1
Parts List	2-1
Installation Prerequisite	2-1
Installation Instructions	2-1

TLA7KUP Option 19

TLA7KUP Option 19: TLA700 Series Benchtop Mainframe	
Upgrade	3-1
Instruments	3-1
Minimum Tool and Equipment List	3-1
Parts List	3-1
Installation Prerequisite	3-2
Installation Overview	3-2
Installation Instructions	3-4
Installing the Bracket Kit	3-20

TLA7KUP Option 29

TLA7KUP Option 29: Floppy Disk Drive	4-1
Instruments	4-1
Minimum Tool and Equipment List	4-1
Parts List	4-1
Installation Prerequisite	4-1

Installation Instructions	4-1
Attach the Upgrade Kit Label to the Instrument	4-1

TLA7KUP Option 39

TLA7KUP Option 39: USB Security Block for TLA7012 Series	
Logic Analyzers	5-1
Instruments	5-1
Minimum Tool and Equipment List	5-1
Parts List	5-1
Installation Prerequisite	5-1
Installation Instructions	5-2

TLA7KUP Option 41

TLA7KUP Option 41: TLA Application Software and Windows	
Operating System Upgrade	6-1
Instruments	6-1
Minimum Tool and Equipment List	6-1
Parts List	6-2
TLA7KUP Option 41: Application Software and Windows	
Operating System Instructions	6-3
Install Software	6-3
Upgrade the Instrument Firmware	6-4
Update TLA Module Firmware	6-5
Calibrate the Instrument	6-8
Installing the TLA Application Software on a PC	6-9
Attach the Upgrade Kit Label to the Instrument	6-11

TLA7KUP Option 42

TLA7KUP Option 42: TLA Application Software Upgrade	7-1
Instruments	7-1
Installation Prerequisite	7-1
Parts List	7-1
Minimum Tool and Equipment List	7-1
TLA7KUP Option 42: Application Software Instructions	7-3
Upgrade Instruction Overview	7-3
Update the Software	7-4
Upgrade the Instrument Firmware	7-4
Update TLA Module Firmware	7-5
Calibrate the Instrument	7-8
Installing the TLA Application Software on a PC	7-9
Attach the Upgrade Kit Label to the Instrument	7-11

TLA7KUP Option IF

TLA7KUP Option IF: Upgrade Installation Service	8-1
Instruments	8-1

TLA7KUP Option IN

TLA7KUP Option IN: On-Site Installation Service	9-1
Instruments	9-1

List of Figures

Figure 1-1: Kit label locations	1-2
Figure 2-1: Instrument enclosure detail	2-2
Figure 2-2: Remove the front-panel trim screws	2-3
Figure 2-3: Tilt the front panel forward for cable access	2-3
Figure 2-4: Front panel cable locations	2-4
Figure 2-5: Dress the cables properly	2-4
Figure 2-6: Kit label locations	2-5
Figure 3-1: Firmware update configuration	3-3
Figure 3-2: Removing the instrument cover	3-4
Figure 3-3: Removing the instrument front panel	3-5
Figure 3-4: Installing the new front panel	3-6
Figure 3-5: Mainframe serial number location	3-7
Figure 3-6: Adding the mainframe serial number to the Interface Module label	3-7
Figure 3-7: Remove the cable cover	3-8
Figure 3-8: Check for an adapter cable and disconnect the cable ..	3-8
Figure 3-9: Set the fan jumpers on the Enhanced Monitor Card ..	3-9
Figure 3-10: Connect the flash jumper	3-10
Figure 3-11: LAN Connection Properties dialog box	3-11
Figure 3-12: IP Properties dialog box	3-12
Figure 3-13: TLA Network Search dialog box	3-13
Figure 3-14: Firmware Loader dialog box	3-14
Figure 3-15: List of modules available for firmware update	3-15
Figure 3-16: New front panel display and control buttons	3-16
Figure 3-17: Mainframe Firmware dialog box	3-17
Figure 3-18: Front panel upgrade label location	3-18
Figure 3-19: Setting the IP address	3-19
Figure 3-20: Bracket kit for the TLA7016 benchtop mainframe installed	3-20
Figure 3-21: Seeking a reply from the mainframe	3-21
Figure 4-1: Kit label locations	4-2

Figure 5-1: Remove the instrument enclosure	5-3
Figure 5-2: Remove the front-panel trim screws	5-4
Figure 5-3: Tilt the front panel forward for cable access	5-4
Figure 5-4: Disconnect the USB cables from the front panel	5-5
Figure 5-5: Dress the cables properly	5-5
Figure 5-6: Mount the main lock housing to the instrument	5-6
Figure 5-7: Connect the cables	5-6
Figure 5-8: Slide the housing cover into place	5-7
Figure 5-9: Attach a padlock	5-7
Figure 5-10: Attach the revision and kit labels	5-8
Figure 5-11: Attach the notification label to the rear of the instrument	5-8
Figure 5-12: Attach the notification label over the front-panel USB connectors	5-9
Figure 6-1: Flash programming pins	6-6
Figure 6-2: Revision and kit label locations	6-8
Figure 6-3: Revision and kit label locations	6-11
Figure 7-1: Flash programming pins	7-6
Figure 7-2: Revision and kit label locations	7-8
Figure 7-3: Revision and kit label locations	7-11

List of Tables

Table i: TLA7000 Series logic analyzers eligible for upgrades	ix
Table ii: TLA7KUP Logic Analyzer Field Upgrade Matrix	x
Table 1-1: TLA7KUP Option 15 parts list	1-1
Table 2-1: TLA7KUP Option 18 parts list	2-1
Table 3-1: TLA7KUP Option 19 parts list	3-1
Table 3-2: Preset IP addresses	3-19
Table 4-1: TLA7KUP Option 29 parts list	4-1
Table 5-1: TLA7KUP Option 39 parts list	5-1
Table 6-1: TLA7KUP Option 41 parts list	6-2
Table 6-2: TLA user file suffixes	6-3
Table 6-3: TLA firmware files	6-7
Table 7-1: TLA7KUP Option 42 parts list	7-1
Table 7-2: TLA firmware files	7-7

General Safety Summary

Review the following safety precautions to avoid injury and prevent damage to this product or any products connected to it.

To avoid potential hazards, use this product only as specified.

Only qualified personnel should perform service procedures.

While using this product, you may need to access other parts of a larger system. Read the safety sections of the other component manuals for warnings and cautions related to operating the system.

To Avoid Fire or Personal Injury

Use Proper Power Cord. Use only the power cord specified for this product and certified for the country of use.

Connect and Disconnect Properly. Do not connect or disconnect probes or test leads while they are connected to a voltage source.

Ground the Product. This product is grounded through the grounding conductor of the power cord. To avoid electric shock, the grounding conductor must be connected to earth ground. Before making connections to the input or output terminals of the product, ensure that the product is properly grounded.

Observe All Terminal Ratings. To avoid fire or shock hazard, observe all ratings and markings on the product. Consult the product manual for further ratings information before making connections to the product.

The inputs are not rated for connection to mains or Category II, III, or IV circuits.

Do not apply a potential to any terminal, including the common terminal, that exceeds the maximum rating of that terminal.

Power Disconnect. The power switch disconnects the product from the power source. See instructions for the location. Do not block the power switch; it must remain accessible to the user at all times.

Power Disconnect. The power cord disconnects the product from the power source. Do not block the power cord; it must remain accessible to the user at all times.

Do Not Operate Without Covers. Do not operate this product with covers or panels removed.

Do Not Operate With Suspected Failures. If you suspect there is damage to this product, have it inspected by qualified service personnel.

Avoid Exposed Circuitry. Do not touch exposed connections and components when power is present.

Replace Batteries Properly. Replace batteries only with the specified type and rating.

Use Proper Fuse. Use only the fuse type and rating specified for this product.

Do Not Operate in Wet/Damp Conditions.

Do Not Operate in an Explosive Atmosphere.

Keep Product Surfaces Clean and Dry.

Provide Proper Ventilation. Refer to the manual's installation instructions for details on installing the product so it has proper ventilation.

Terms in this Manual

These terms may appear in this manual:



WARNING. Warning statements identify conditions or practices that could result in injury or loss of life.



CAUTION. Caution statements identify conditions or practices that could result in damage to this product or other property.

Symbols and Terms on the Product

These terms may appear on the product:

- DANGER indicates an injury hazard immediately accessible as you read the marking.
- WARNING indicates an injury hazard not immediately accessible as you read the marking.
- CAUTION indicates a hazard to property including the product.

The following symbols may appear on the product:

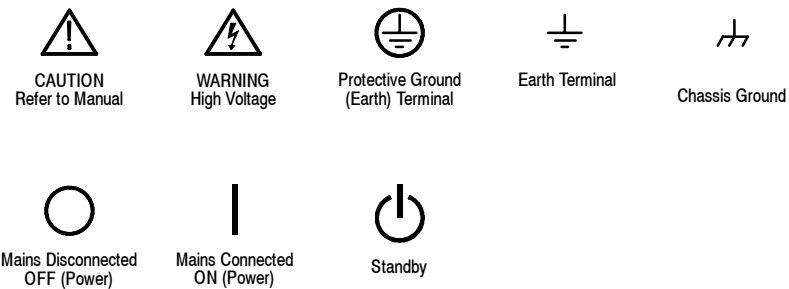

Service Safety Summary

Only qualified personnel should perform service procedures. Read this *Service Safety Summary* and the *General Safety Summary* before performing any service procedures.

Do Not Service Alone. Do not perform internal service or adjustments of this product unless another person capable of rendering first aid and resuscitation is present.

Disconnect Power. To avoid electric shock, switch off the instrument power, then disconnect the power cord from the mains power.

Use Care When Servicing With Power On. Dangerous voltages or currents may exist in this product. Disconnect power, remove battery (if applicable), and disconnect test leads before removing protective panels, soldering, or replacing components.

To avoid electric shock, do not touch exposed connections.

Environmental Considerations

This section provides information about the environmental impact of the product.

Product End-of-Life Handling

Observe the following guidelines when recycling an instrument or component:

Equipment Recycling. Production of this equipment required the extraction and use of natural resources. The equipment may contain substances that could be harmful to the environment or human health if improperly handled at the product's end of life. In order to avoid release of such substances into the environment and to reduce the use of natural resources, we encourage you to recycle this product in an appropriate system that will ensure that most of the materials are reused or recycled appropriately.



The symbol shown to the left indicates that this product complies with the European Union's requirements according to Directive 2002/96/EC on waste electrical and electronic equipment (WEEE). For information about recycling options, check the Support/Service section of the Tektronix Web site (www.tektronix.com).

Mercury Notification. This product uses an LCD backlight lamp that contains mercury. Disposal may be regulated due to environmental considerations. Please contact your local authorities or, within the United States, the Electronics Industries Alliance (www.eiae.org) for disposal or recycling information.

Restriction of Hazardous Substances

This product has been classified as Monitoring and Control equipment, and is outside the scope of the 2002/95/EC RoHS Directive. This product is known to contain lead, cadmium, mercury, and hexavalent chromium.

Preface

This instruction manual contains specific information about the TLA7KUP logic analyzer field upgrades. The logic analyzer field upgrades consist of software and hardware options for the TLA7000 Series Logic Analyzers.

Products Eligible for TLA7KUP Upgrades

Table i lists all of the TLA7000 series logic analyzers eligible for upgrades via the TLA7KUP field upgrade kits. Review Table i to determine if your logic analyzer is eligible for an upgrade and then use Table ii on page x, to explore possible upgrade paths.

Table i: TLA7000 Series logic analyzers eligible for upgrades

Configuration	Operating system	TLA application software
TLA7012 Portable Standard TLA7016 Benchtop Standard TLA7PC1 Benchtop Controller Standard	Microsoft Windows XP Professional 32-bit	Version 5.1
TLA7012 Portable Standard	Microsoft Windows XP Professional 32-bit	Version 5.0
TLA720/TLA721/TLA7XM Benchtop Standard	Windows 2000 Professional	Version 4.4 or below

NOTE. *The TLA7016 Benchtop Mainframe does NOT include a PC controller.*

The TLA7KUP upgrade kits are designed for “One TLA7KUP upgrade kit per TLA7012 or TLA7016 with TLA7PC1.” If you want to upgrade multiple mainframes, you must order one TLA7KUP upgrade kit with the appropriate options for each mainframe.

The latest TLA Application Software has been tested and can be installed and will be supported by Tektronix only on the Tektronix-supplied version of Microsoft Windows XP Professional.

Table ii: TLA7KUP Logic Analyzer Field Upgrade Matrix

New capability desired	Current configuration and TLA software version	Current operating system	Please order
<p>Add New Software Features Add new functionality to existing TLA7000 logic analyzers by upgrading to the latest TLA Application Software¹.</p> <p>Version 5.1 requires Microsoft Windows XP Professional Operating System.</p>	<p>TLA7012 Portable Std with TLA SW V5.1</p> <p>TLA7016 Benchtop Std with TLA SW V5.1</p> <p>TLA7PC1 Benchtop Controller Std with TLA SW V 5.1</p>	<p>Microsoft Windows XP Professional 32-bit</p>	<p>-</p> <p>TLA7KUP Option 42 (without HD recovery CD)</p>
<p>Add New iView External Oscilloscope Capability Add new iView capability to view data from TDS oscilloscopes correlated directly on the TLA7000 logic analyzer display².</p> <p>Requires latest TLA Application Software and Microsoft Windows XP Professional Operating System.</p>	<p>TLA7012 Portable Std with TLA SW V5.1</p> <p>TLA7016 Benchtop Std with TLA SW V5.1</p> <p>TLA7PC1 Benchtop Controller Std with TLA SW V 5.1</p>	<p>Microsoft Windows XP Professional 32-bit</p>	<p>TLA7KUP Option 15</p> <p>TLA7KUP Option 15</p> <p>TLA7KUP Option 42 (Without restore media)</p>
<p>Upgrade Logic Analyzer State Speed and Record Length Enhance your current TLA7000 series logic analyzer modules by increasing state speed or record length. Once installed on your instrument, the PowerFlex Utility software will inform you what upgrades are available. Instructions to obtain an upgrade are provided.</p>	<p>Any TLA7000 series logic analyzer with TLA SW V5.0 (or above)</p>	<p>-</p>	<p>TLA7KUP Option PF or</p> <p>visit www.tektronix.com/LA for the PowerFlex Utility software</p>

¹ Version 1.8 of the PatGen Application Software is available either as part of the latest TLA Application Software or on the Web. Please visit our website at www.tektronix.com/la.

² For a list of supported TDS oscilloscopes, please visit our website at www.tektronix.com/la.

Table ii: TLA7KUP Logic Analyzer Field Upgrade Matrix (Cont.)

New capability desired	Current configuration and TLA software version	Current operating system	Please order
Add New Measurement Modules to Existing Mainframe: Add new or existing TLA7Axx/NAx Logic Analyzer or TLA7PG2 Pattern Generator modules to your new or existing mainframe. Requires latest TLA Application Software and Windows XP Professional Operating system.	TLA7012 Portable Std with TLA SW V5.1	Microsoft Windows XP Professional 32-bit	-
	TLA7016 Benchtop Std with TLA SW V5.1		
	TLA7PC1 Benchtop Controller Std with TLA SW V 5.1		
	TLA7012 Portable Std with TLA SW V5.0	Microsoft Windows XP Professional 32-bit	TLA7KUP Option 42 (Without restore media)
Add Touch Screen to the TLA7012 Portable Mainframe	TLA7012 Std Portable with TLA SW V5.1 or V5.0	Microsoft Windows XP Professional 32-bit	TLA7KUP Option 18
Convert a TLA720/721/7XM Benchtop Mainframe to a TLA7016 Benchtop Mainframe: Requires latest TLA Application Software and Windows XP Professional 32-bit Operating system. External PC or TLA7PC1 require latest TLA Application Software and operating system.	TLA720 Std with TLA SW V5.1	Microsoft Windows XP Professional 32-bit	TLA7KUP Option 19 TLA7KUP Option 42 (External PC with Microsoft Windows XP Professional 32-bit or TLA7PC1 required to load TLA SW)
	TLA721 Std with TLA SW V5.1		
	TLA7XM Std		
	TLA720 Std with TLA SW V4.4 or below	Microsoft Windows 2000 Professional	
	TLA721 Std with TLA SW V4.4 or below		
	TLA7XM Std		
Add 3.5-inch USB Floppy Disk Drive	Any TLA7000 series logic analyzer with TLA SW V5.0 (or above)	-	TLA7KUP Option 29
Add USB Security Block: Allows you to disable USB ports and yet continue to use the USB keyboard and mouse.	Any TLA7012 Portable Std	-	TLA7KUP Option 39
Add Cart: Add your choice of either the K4000 or LACART instrument cart.	Any TLA7012 or TLA7016 mainframe	-	Choice of either K4000 or LACART
Add Rackmount Kit	TLA7012 Portable Std	-	020-2664-xx
	TLA7016 Benchtop Std	-	020-2369-xx
Add Wheeled Transport Case for TLA7000 Series Mainframes	TLA7012 Portable Std	-	016-1522-xx
	TLA7016 Benchtop Std	-	016-1651-xx

Service and Upgrade Notes

To prevent personal injury or damage to the instrument, consider the following requirements before attempting service:

- Read the *General Safety Summary* and *Service Safety Summary* found at the beginning of this manual.
- Only qualified service personnel should perform the procedures in this manual.

Be sure to follow all warnings, cautions and notes.

Adjustment and Certification Interval

Generally, you should perform the adjustments and performance verification procedures for the mainframes described in the *Tektronix Logic Analyzer Series Product Specifications and Performance Verification Technical Reference Manual* (071-1763-xx) once per year, or following repairs that may affect adjustment or calibration. The adjustment and verification procedures for individual modules are described in the respective module service manuals.

Service Offerings

Tektronix provides service to cover repair under warranty as well as other services that are designed to meet your specific service needs.

Whether providing warranty repair service or any of the other services listed below, Tektronix service technicians are equipped to service your logic analyzer. Services are provided at Tektronix Services Centers.

Warranty Repair Service

The warranty for this product is located behind the title page in this manual. Tektronix technicians provide warranty service at most Tektronix service locations worldwide. The Tektronix product catalog lists all service locations worldwide, or you can visit us on our *Customer Services World Center* web site at:

Tektronix.com/Measurement/Service

Calibration and Repair Service

In addition to warranty repair, Tektronix Service offers calibration and other services which provide solutions to your service needs and quality standards compliance requirements.

The following services can be tailored to fit your requirements for calibration and/or repair of your logic analyzer.

Service Options. Tektronix service options can be selected at the time you purchase your instrument. You select these options to provide the services that best meet your service needs.

Service Agreements. If service options are not added to the instrument purchase, then service agreements are available on an annual basis to provide calibration services or post-warranty repair coverage. Service agreements may be customized to meet special turn-around time and/or on-site requirements.

Service on Demand. Tektronix offers calibration and repair services on a “per-incident” basis that is available with standard prices.

Self Service. Tektronix supports repair to the replaceable-part level by providing for circuit board exchange.

Use this service to reduce down-time for repair by exchanging circuit boards for remanufactured ones. Tektronix ships updated and tested exchange boards. Each board comes with a 90-day service warranty.

For More Information. Contact your local Tektronix service center or sales engineer for more information on any of the Calibration and Repair Services just described.



TLA7KUP Option 15

TLA7KUP Option 15: iView External Oscilloscope Cable Installation

TLA7KUP option 15 provides the capability of connecting your logic analyzer to an external Tektronix oscilloscope through the iView cable.

Instruments

TLA7000 Series Logic Analyzers

All Serial Numbers

Minimum Tool and Equipment List

No special tools or equipment are required.

Parts List

Table 1-1: TLA7KUP Option 15 parts list

Quantity	Part number	Description
1 ea	012-1614-xx	iView external oscilloscope cable kit (includes USB-to-GPIB & BNC, BNC-to-SMB adapter, and instruction card)
1 ea	N/A	TLA7KUP kit label

Installation Prerequisite

Requires Version 5.1 TLA Application Software or higher, Windows XP Professional operating system, and 512 MB minimum memory. Also requires the latest version of the NI-488.2 software available on the TLA Application software CD; refer to the release notes on the CD for software version history.

Installation Instructions

Online installation instructions are provided within the TLA application through a wizard. After powering on the instrument, select Add iView External Scope from the System menu and follow the online instructions.

Attach the Upgrade Kit Label to the Instrument

After completing the previous steps, you need to install the upgrade kit label on the instrument to indicate that the kit is installed.

Locate the big label on the rear of the instrument, and then attach the TLA7KUP kit label as shown in Figure 1-1.

NOTE. *If there already is an upgrade kit label installed, install the new label just above the old one.*



Figure 1-1: Kit label locations



TLA7KUP Option 18

TLA7KUP Option 18: TLA7012 Touchscreen Installation

TLA7KUP option 18 provides parts and instructions to install a touchscreen display on your TLA7012 Portable Logic Analyzer.

Instruments

TLA7012 Series Logic Analyzers

All Serial Numbers

Minimum Tool and Equipment List

T-15 Torx and 5/16 in nut drivers required.

Parts List

Table 2-1: TLA7KUP Option 18 parts list

Quantity	Part number	Description
1 ea	650-4676-00	Front Panel Display Assembly with Touchscreen panel
1 ea	119-6107-00	Touchscreen stylus, package of 3
1 ea	N/A	TLA7KUP kit label

Installation Prerequisite

Requires Version 5.1 TLA Application Software or higher, Windows XP Professional operating system, and 512 MB minimum mainframe memory.

Installation Instructions

Refer to the illustrations as you perform the following procedures.



CAUTION. To prevent static discharge damage, service the product only in a static-free environment. Observe standard handling precautions for static-sensitive devices while installing this kit. Always wear a grounded wrist strap, grounded foot strap, and static resistant apparel while installing this kit.

- Removal** Begin by removing the instrument enclosure. Refer to Figure 2-1.
1. Disconnect all cords, probes, and modules from the instrument.
 2. Set the instrument on the bottom feet.
 3. Remove the six T-15 screws from the right cover and remove the cover.

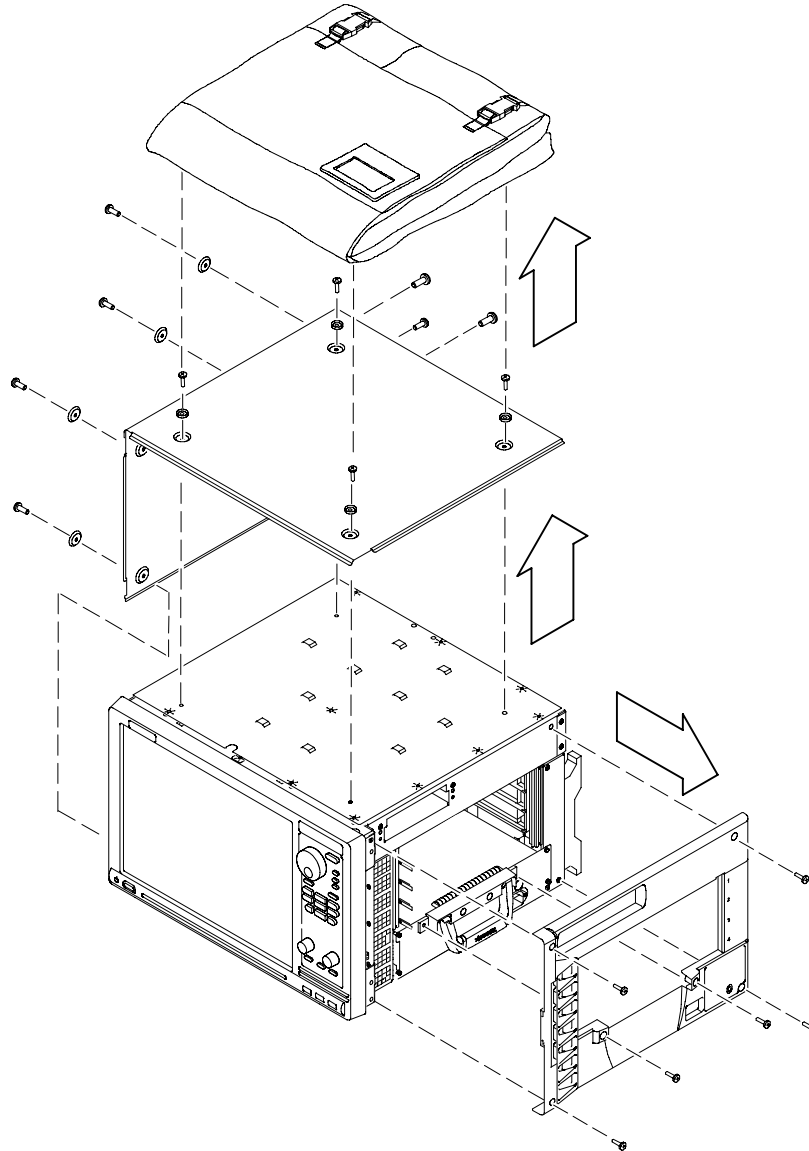

Figure 2-1: Instrument enclosure detail

4. Remove the accessory pouch and snap studs (4 T-15 screws).
5. Remove the four skid feet from the left side (4 T-15 screws).

6. Remove the three remaining T-15 screws from the top left cover and then remove the cover.
7. Set the instrument on the rear feet.
8. Remove the 12 T-15 screws from the front-panel trim. See Figure 2-2.

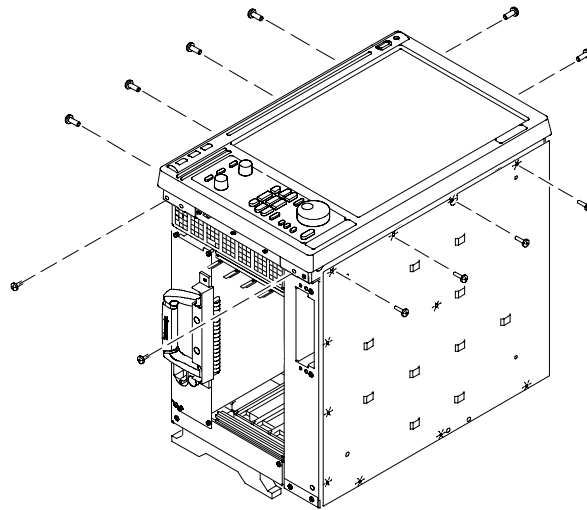

Figure 2-2: Remove the front-panel trim screws

9. Set the instrument back on the bottom feet.
10. Tilt the top of the front panel out about 8 inches. See Figure 2-3.

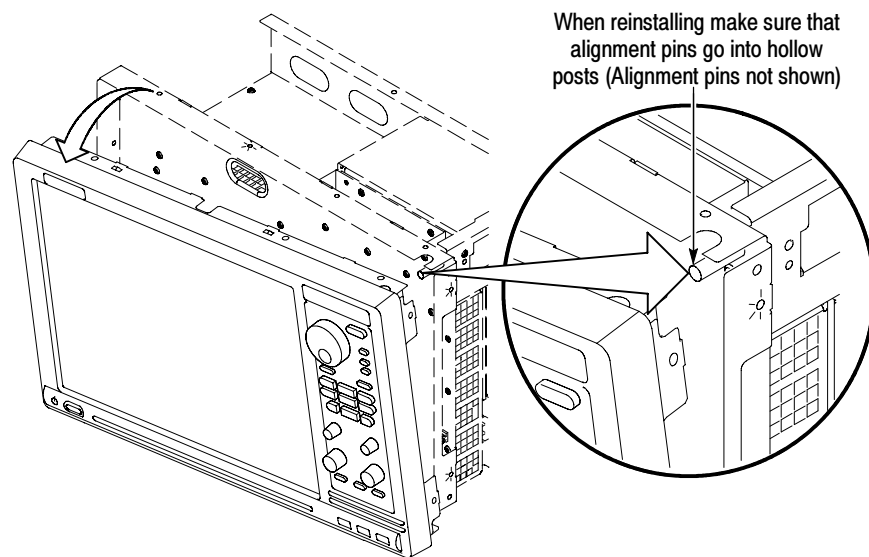

Figure 2-3: Tilt the front panel forward for cable access

11. Disconnect the two display cables and three USB cables from the front panel assembly. See Figure 2-4.
12. Remove the ground wire with a 5/16 in driver.

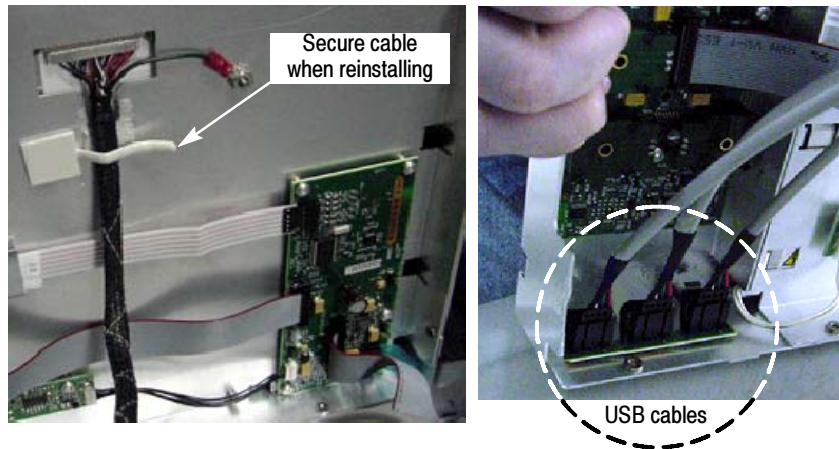

Figure 2-4: Front panel cable locations

13. Remove the front panel assembly.

Installation

Install the new touchscreen display assembly by following steps 1 through 13 in reverse. The following hints will help you complete a successful installation:

- When connecting the display cable, carefully line up the centers of the plug and socket before pressing them together. This may require some patience.
- To avoid damaging the USB and DVD cables, dress the cables properly just before you attach the new display assembly to the chassis. See Figure 2-5.

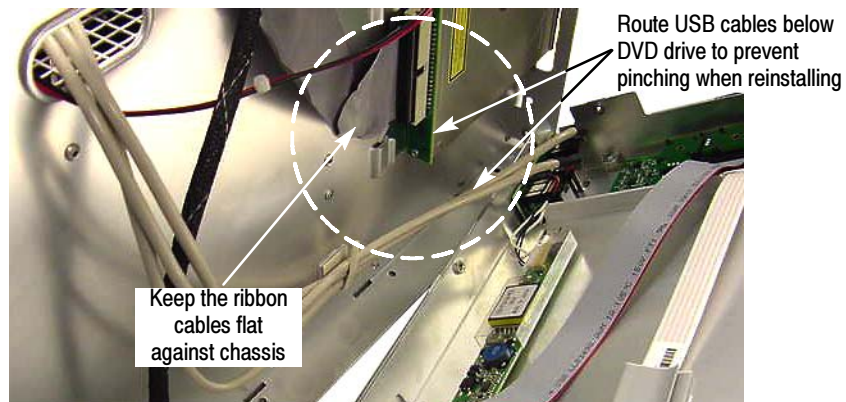

Figure 2-5: Dress the cables properly

Calibrate the Touchscreen

Verify the touchscreen operation by doing the following steps.

1. Power on the instrument.
2. In the Windows Quick Launch Taskbar, double-click on the Pointing Device icon (small mouse graphic). The Touch Screen Properties appears.
3. Click Calibrate and follow the on-screen instructions to perform the alignment routine. Use one of the styluses provided with this kit to ensure the best accuracy.

You can also customize some of the functions of your touchscreen in the Touch Screen Properties window. Right-click on the selection text to view a description of the function.

Attach the Upgrade Kit Label to the Instrument

After completing the previous steps, you need to install the upgrade kit label on the instrument to indicate that the kit is installed.

Locate the big label on the rear of the instrument, and then attach the TLA7KUP kit label as shown in Figure 2-6.

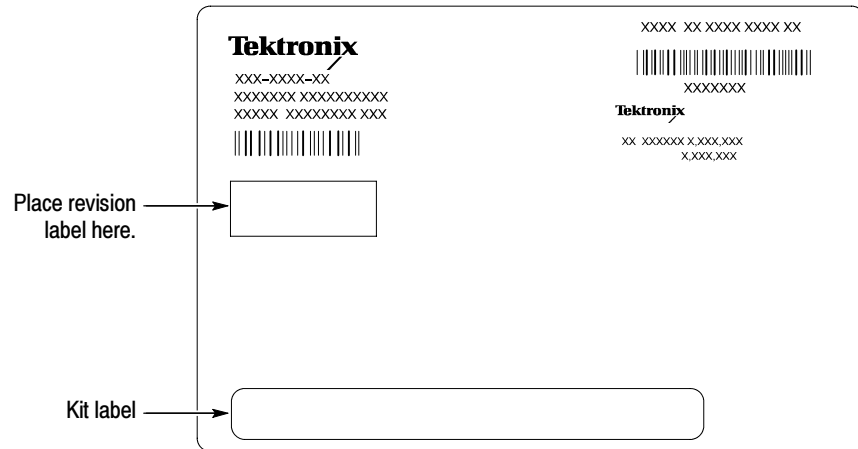

Figure 2-6: Kit label locations



TLA7KUP Option 19

TLA7KUP Option 19: TLA700 Series Benchtop Mainframe Upgrade

TLA7KUP option 19 provides parts and instructions to upgrade your TLA72X or TLA7XM benchtop mainframe to a TLA7016 Benchtop Mainframe. This kit includes a new Front Panel and Interface Module that, when installed, require a separate PC controller to operate the mainframe. See *Installation Prerequisite* on page 3-2 for controller and software requirements.

This kit also includes a set of brackets that allow you to conveniently secure the TLA7PC1 controller, GbE switch, and TL708EX Hub to your benchtop mainframe without purchasing a separate 19-inch instrument rack.

Instruments

TLA72X or TLA7XM Series Logic Analyzers

All Serial Numbers

Minimum Tool and Equipment List

T-7 and T-10 Torx, P2 PoziDriv, P1 Phillips Drivers, Needle-nose pliers

Parts List

Table 3-1: TLA7KUP Option 19 parts list

Quantity	Part number	Description
1 ea	650-4868-00	TLA7016 Front Panel w/ 2.5-inch Electroluminescent Display
1 ea	650-4733-00	TLA7016 Single-Slot Interface Module
1 ea	174-5225-00	LAN cable, straight through, RJ-45, shielded, 15 ft
1 ea	174-5019-00	TekLink cable, 2 m
5 ea	131-4356-xx	Jumper with pull-tab
1 ea	407-5127-00	Left side Benchtop System Mounting Bracket w/ preinstalled mounting hardware
1 ea	407-5132-00	Right side Benchtop System Mounting Bracket w/ preinstalled mounting hardware
1 sheet	355-1542-00	Software revision labels
1 ea	N/A	TLA7KUP kit label

Installation Prerequisite

The controller PC that is connected to the benchtop mainframe must be one of the following devices (referred to as the controller PC throughout this document.)

- User-supplied PC
- Tektronix TLA7PC1 Benchtop Controller
- Tektronix TLA7012 Portable Mainframe
- Tektronix TLA520X Logic Analyzer

Also, the controller PC that you use requires:

- Version 5.1 TLA Application Software or higher
- Windows XP Professional 32-bit operating system
- 512 MB minimum memory

See the *Preface* in this manual for information on options to upgrade your TLA application software and OS software.

Installation Overview

These procedures must be performed in the following order:

1. Replace the existing front panel with the new display front panel.
2. Replace the existing TLA72X Benchtop Controller with the new TLA7016 Interface Module.
3. Make the proper jumper settings on the Enhanced Monitor Card.
4. Configure the IP properties of the controller PC (loaded with correct software).
5. Connect the LAN cable from the controller PC to the mainframe and upgrade the firmware.
6. Verify the installation and apply the upgrade label to the mainframe.
7. Connect to your test system, using the TekLink cable if necessary.

Figure 3-1 on page 3-3 shows the connections and describes the network settings for the firmware upgrade.

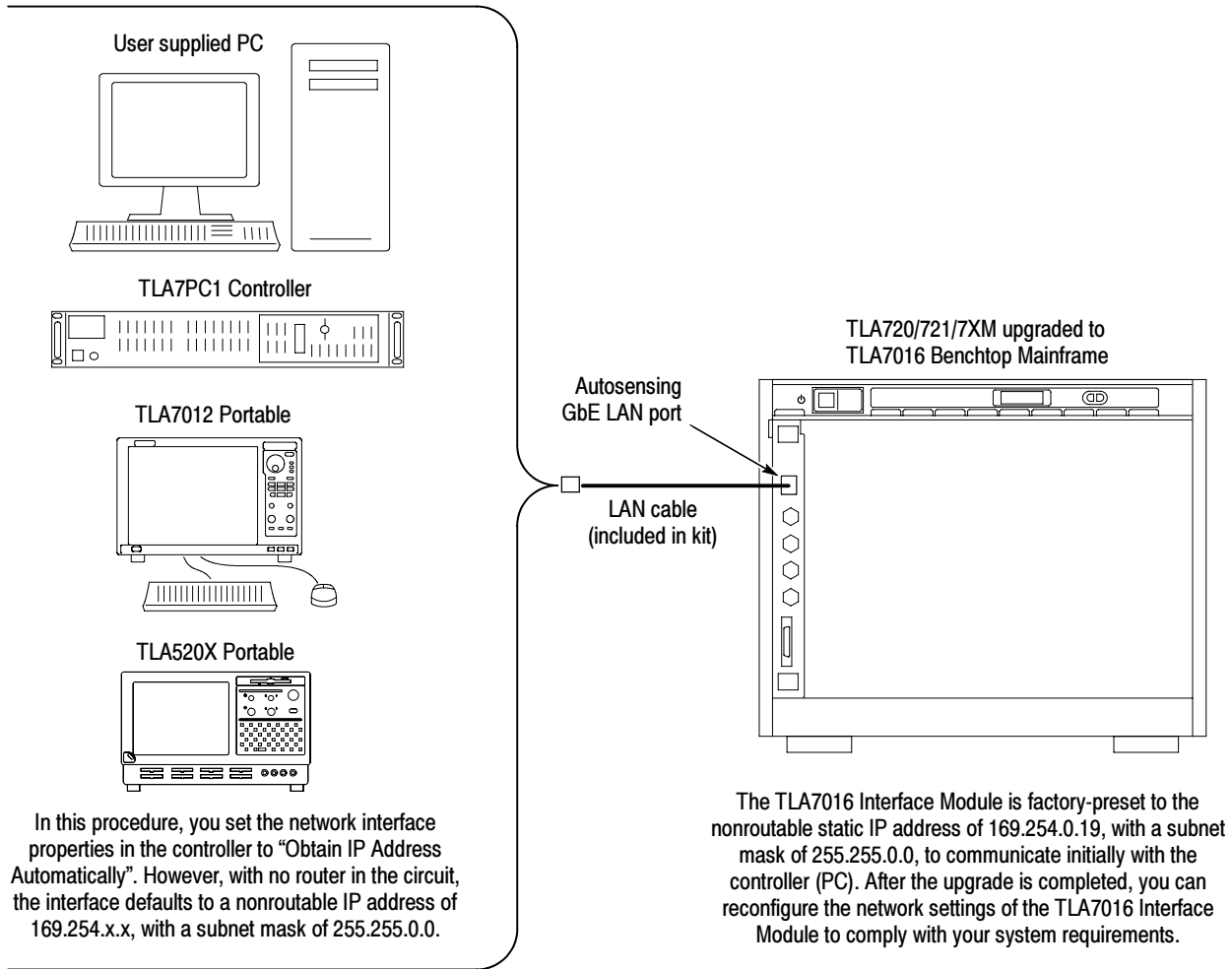

Figure 3-1: Firmware update configuration

Installation Instructions

Refer to the illustrations as you perform the following procedures.



CAUTION. To prevent static discharge damage, service the product only in a static-free environment. Observe standard handling precautions for static-sensitive devices while installing this kit. Always wear a grounded wrist strap, grounded foot strap, and static resistant apparel while installing this kit.

Front Panel Removal

Remove the front panel by performing the following steps:

1. Disconnect all cords, probes, and modules from the instrument.
2. Set the instrument on the bottom feet.
3. Remove the eight T-7 screws on the top of the instrument. See Figure 3-2.

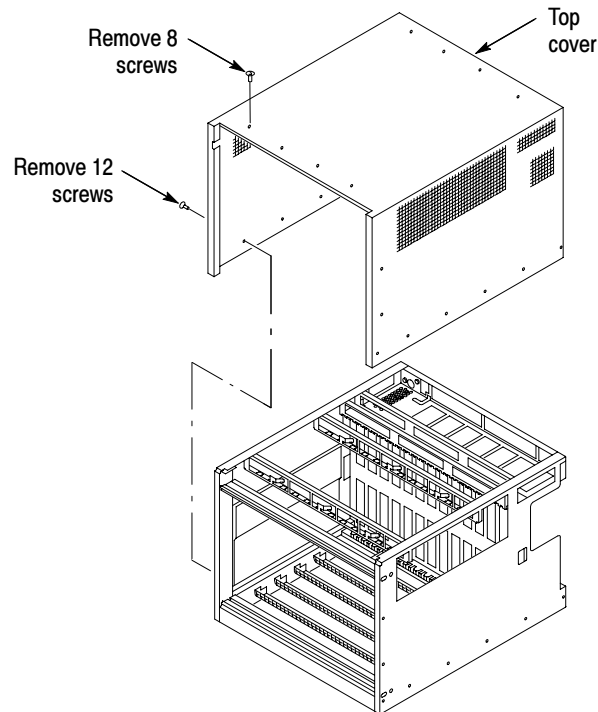

Figure 3-2: Removing the instrument cover

4. Remove the twelve T-10 screws, six on each side of the instrument.
5. Pull the top cover off of the instrument.

6. Note the orientation of the power switch. The green LED is toward the front-left side. (See Figure 3-3). You will remove the switch from the existing front panel and reinstall it in the new front panel.
7. Using needle-nose pliers, remove the five wires from the power switch. (The color-coded connections are shown later in the installation procedure).
8. Remove the two T-7 screws from the front panel and remove the front panel.

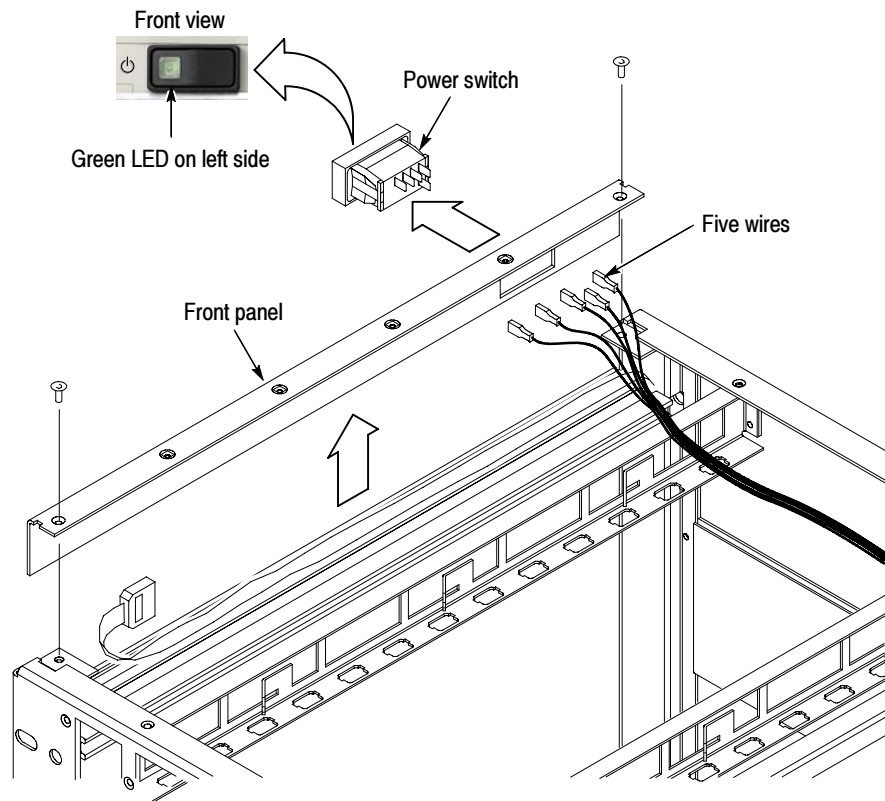

Figure 3-3: Removing the instrument front panel

9. Unsnap the power switch from the front panel by squeezing the snaps on each side of the switch and pushing the switch through the front of the panel.

Front Panel Installation

Install the new front panel by performing the following steps:

1. Orient the power switch to the new front panel so that the four terminals are on top, and the green LED is toward the front-left side. See Figure 3-4.
2. Snap the power switch into the new front panel.
3. Connect the wires to the power switch as shown in Figure 3-4.

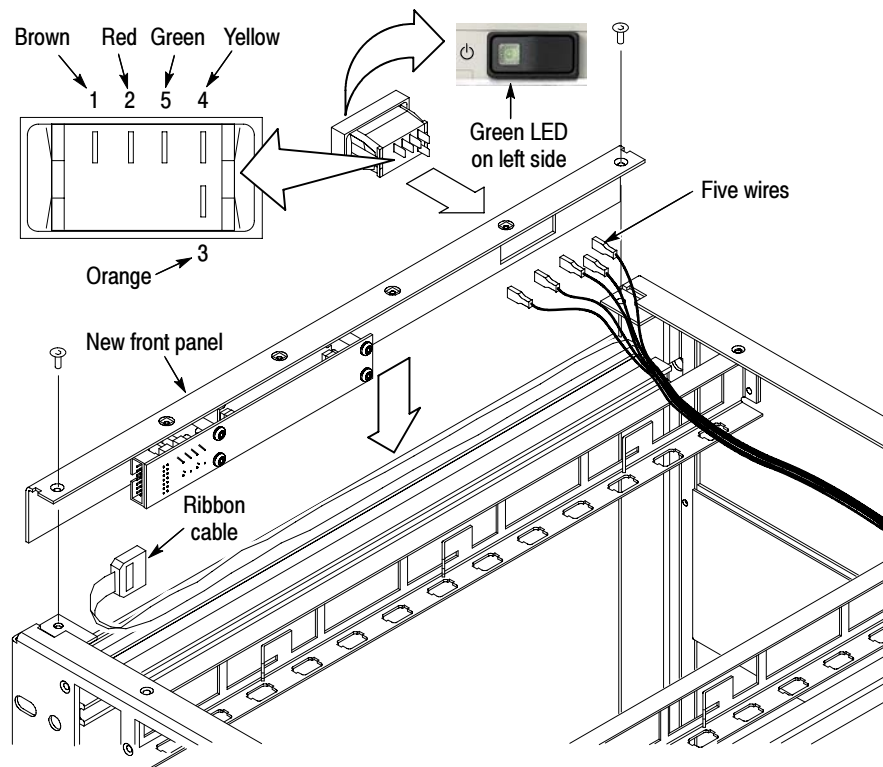

Figure 3-4: Installing the new front panel

4. Connect the ribbon cable from the mainframe to the new front panel.
5. Position the front panel in the chassis. If there is a plastic cable retainer in the way, remove it. Dress the ribbon cable around the display board to avoid pinching the cable.
6. Dress the excess power switch cable towards the back of the chassis, away from the card guides.
7. Attach the front panel to the chassis with one T-7 screw on each side.
8. Replace the cover and partially install the side cover screws first, and then the top screws, until the cover is aligned and all of the screws are started.
9. Tighten all of the cover screws.

Interface Module Installation

Continue by installing the new TLA7016 Interface Module:

1. Loosen the four Phillips P1 mounting screws (two each on the top and bottom), and remove the existing TLA720/721 Benchtop Controller.
2. Get the serial number of the TLA720/721/7XM mainframe that you are upgrading. It is located on a small white label below the power cord. See Figure 3-5.

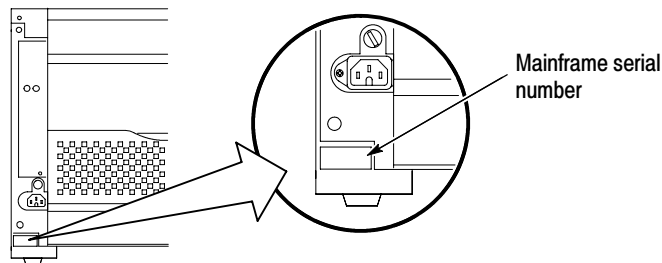

Figure 3-5: Mainframe serial number location

3. Write the mainframe serial number on the Replacement For Serial Number label included in the kit. See Figure 3-6.
4. Affix the Replacement For Serial Number Label to the large white label on the side of the new TLA7016 Interface Module. See Figure 3-6.

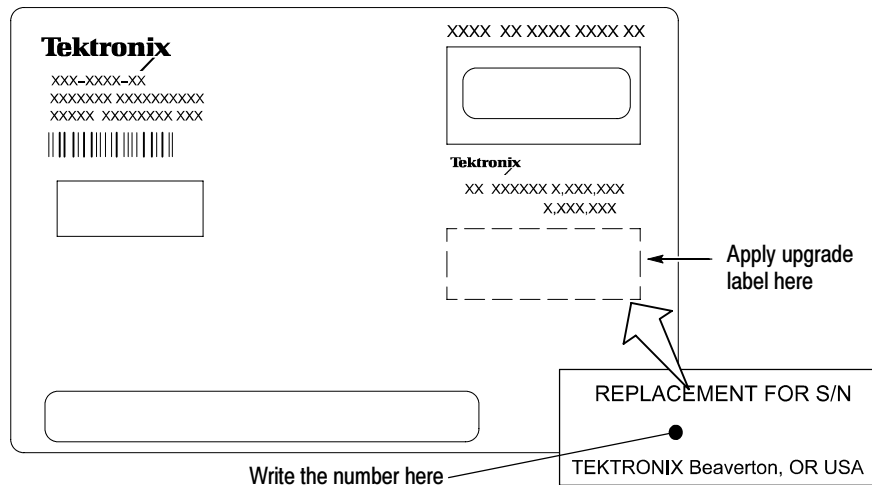

Figure 3-6: Adding the mainframe serial number to the Interface Module label

5. Plug the new TLA7016 Interface Module into the first slot (slot 0) of the mainframe and tighten the two P1 mounting screws.

Set the Jumpers on the Enhanced Monitor Card

The next steps are done at the back of the instrument. See Figure 3-7.

1. On the Enhanced Monitor Card, loosen the middle captive P1 screw and remove the cable cover near the middle of the card.

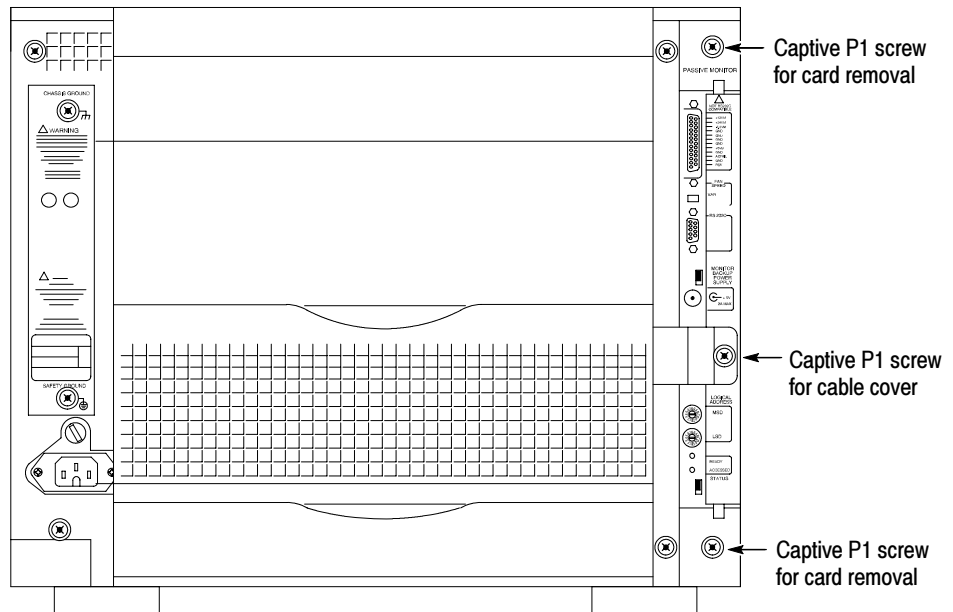

Figure 3-7: Remove the cable cover

2. Disconnect the cable from the Enhanced Monitor Card. There may be a 3-inch adapter cable on the end of the fan cable. See Figure 3-8. The cable configuration will be used to determine the proper jumper settings in step 5.

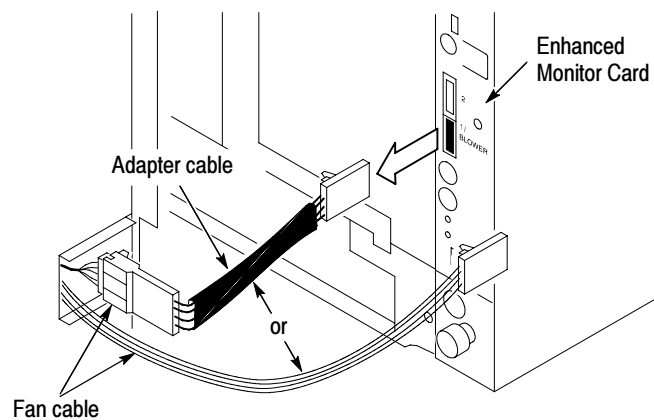

Figure 3-8: Check for an adapter cable and disconnect the cable

3. Loosen the top and bottom captive P1 screws.
4. Pull the Enhanced Monitor Card out of the mainframe.
5. Note the pair of jumpers at the top of the Enhanced Monitor Card. See Figure 3-9.
 - a. If your fan has an adapter cable (see step 2), remove the left jumper of the jumper pair.
 - b. If your fan does not have an adapter cable, remove the right jumper of the jumper pair.

NOTE. Correct jumper configuration is important for the new firmware to control the fan properly.

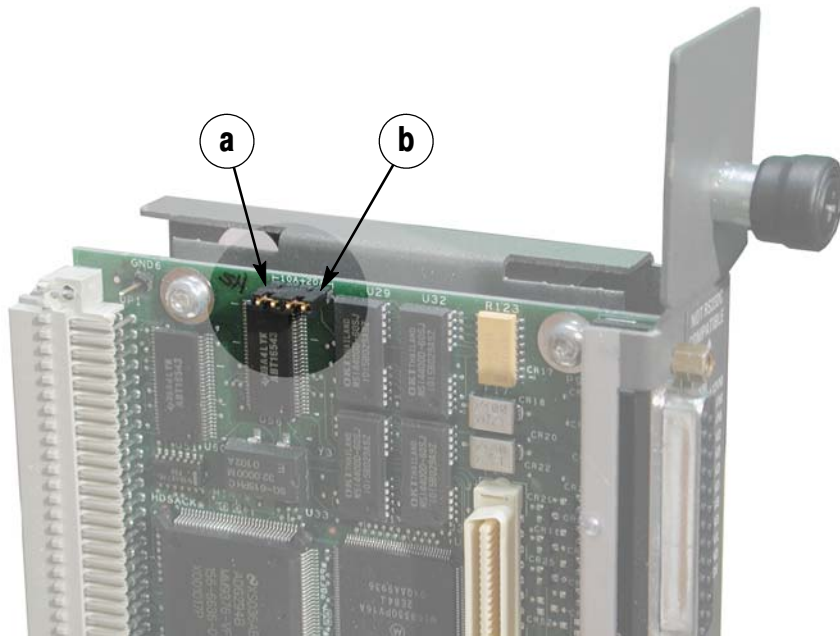

Figure 3-9: Set the fan jumpers on the Enhanced Monitor Card

6. At the back of the Enhanced Monitor Card, connect a jumper on the bottom two flash programming pins. See Figure 3-10.
7. If there are three pins above the flash programming pins, verify that there is another jumper on the upper two pins.

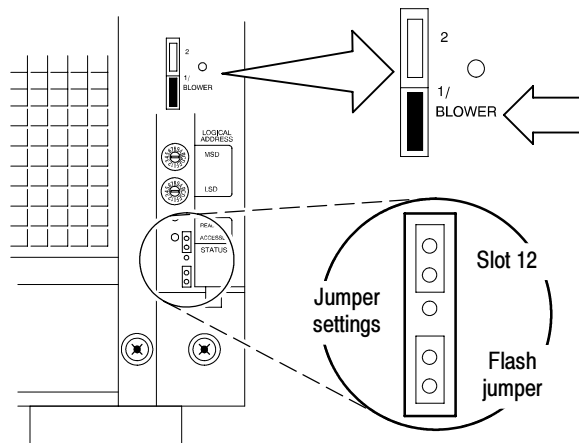

Figure 3-10: Connect the flash jumper

8. Unless you need a static VXI address for the Enhanced Monitor Card, set the arrows on the two white dials to F. This sets the card for VXI dynamic addressing.
9. Plug the Enhanced Monitor Card firmly into the instrument, and tighten the top and bottom P1 screws.
10. Connect the fan cable (or cable adapter) to the connector labeled 1/BLOWER on the Enhanced Monitor Card. See Figure 3-10.
11. Replace the fan cable cover and tighten the P1 screw.

Set the Controller PC IP Address Properties

Continue the installation by configuring the IP address of the controller PC:

1. Power on the controller PC.

NOTE. This upgrade kit requires Version 5.1 or higher TLA Application Software running on the controller PC. If you need to update your software, do so before continuing with these procedures.

2. Click Start → Settings → Control Panel → Network Connections.

3. Right-click the Local Area Connection of the LAN card you will use to communicate with the mainframe (see note), and select Properties.

NOTE. *If you are using a PC for the controller PC, it may have several LAN cards installed. If so, more than one Local Area Connection will appear in the Network Connections dialog box. You must choose which card you will use to communicate with the mainframe, and then use the LAN connector on that card to connect to the mainframe later in this procedure.*

The Local Area Connection Properties dialog box appears. See Figure 3-11.

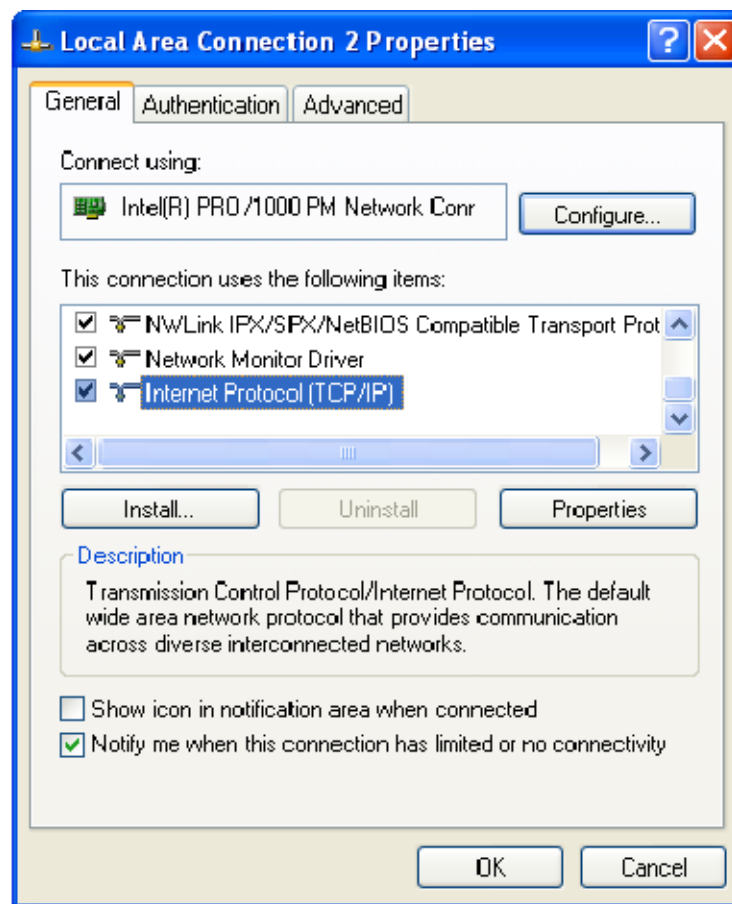

Figure 3-11: LAN Connection Properties dialog box

4. Scroll down the list and select Internet Protocol (TCP/IP).
5. Click Properties. The IP Properties dialog box appears. See Figure 3-12.

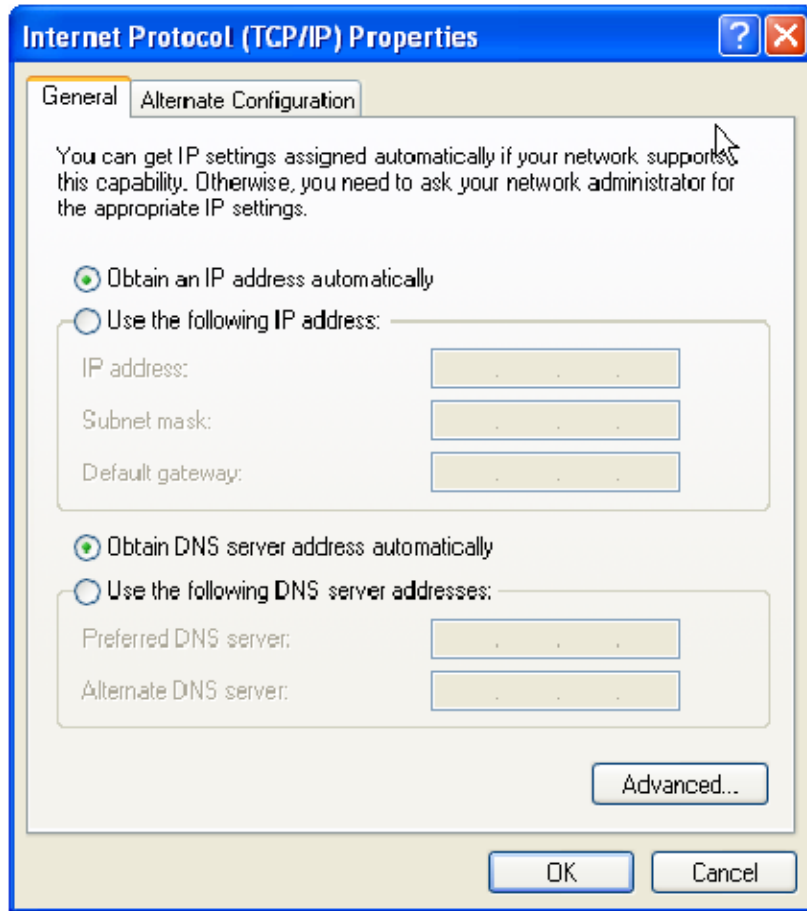

Figure 3-12: IP Properties dialog box

6. Check that the Obtain an IP address automatically radio button is selected. If it is not, select it.
7. Click OK and close the remaining Network Connection windows.

Update Firmware on the Enhanced Monitor Card

Continue the installation by installing three firmware files. In this procedure, you first load the display firmware and check the mainframe display for proper operation, and then load the remaining two files.

1. Connect the LAN cable (included with the kit) from the controller PC to the LAN connector on the TLA7016 Interface Module in the mainframe.
2. Power on the TLA7016 mainframe. Note that no information appears in the new display. This is normal operation while the flash jumper is installed on the Enhanced Monitor Card.
3. Click Start → All Programs → Tektronix Logic Analyzer → TLA Firmware Loader. The Firmware Loader Connection dialog box appears.
4. Click the binoculars icon. The TLA Network Search dialog box appears. See Figure 3-13.

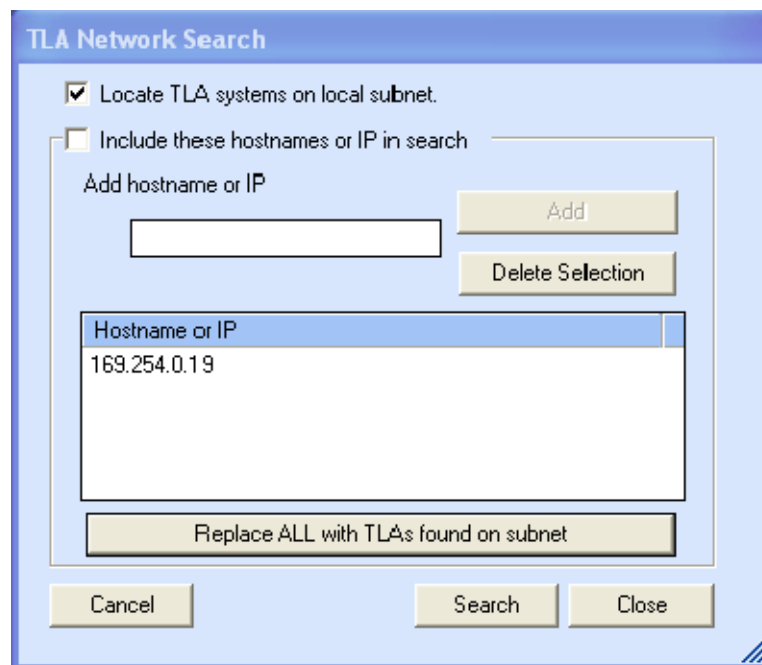

Figure 3-13: TLA Network Search dialog box

5. Select Locate TLA systems in local subnet, and click Search.
6. When the network search is complete, click on the IP address of the TLA7016 listed in the Connection window and click Connect. The Firmware Loader dialog box appears. See Figure 3-14 on page 3-14.

7. The Firmware Loader dialog box includes two Load buttons. Click the bottom Load button (Instrument Module Firmware).

The firmware search progresses without indicating activity, and may take about a minute to complete.

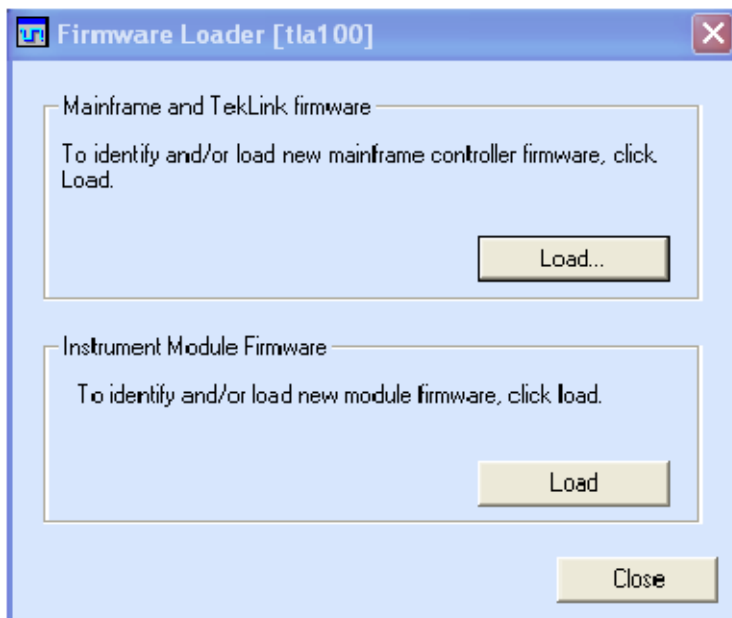

Figure 3-14: Firmware Loader dialog box

8. When the search is finished, the Firmware Loader dialog box reappears with a list of devices. See Figure 3-15 on page 3-15.

9. Click on the TLA BT Fan Ctl module displayed in the Devices Supported list in the top portion of the window. This selects the Enhanced Monitor Card for the firmware upgrade.

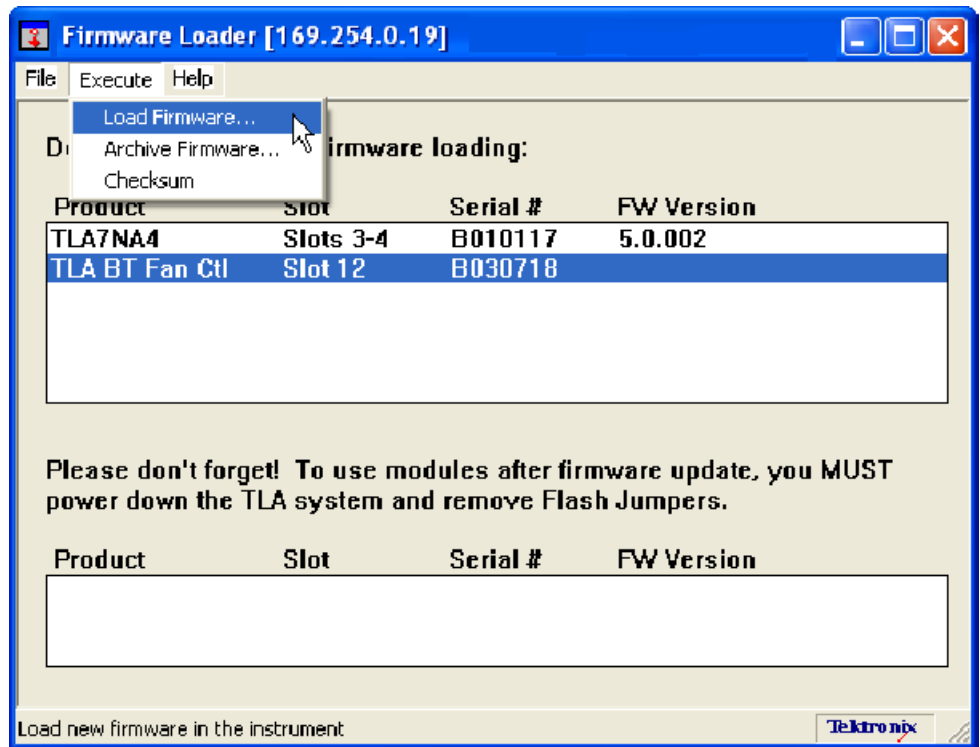

Figure 3-15: List of modules available for firmware update

10. From the Execute pull-down menu, select Load Firmware. A list of firmware files displays.
11. Click TLA7016monitor.lod and click Open.
12. When prompted to confirm your action, click Yes.
13. The firmware flashing process begins and takes about a minute to finish. When the process is done, click OK and exit the program.
14. Power off the mainframe.
15. Remove the lower flash jumper that you installed on the bottom two flash programming pins of the Enhanced Monitor Card. Leave the upper jumper connected.

Check the mainframe display for proper operation:

16. Power on the mainframe. The mainframe initiates a self-test routine, and the following message appears in the display:

TLA7016
Checking Mainframe

When the self-test passes, the following message appears in the display:

TLA7016
Mainframe OK

If the following message appears flashing in the display,

WARN:Clean Filter

then make sure the rear fan air intake is clear of lint or other obstructions, and then press both **Prev** and **Next** buttons simultaneously to clear the message.

After a few seconds, the following message appears in the display:

TLA7016
Ready

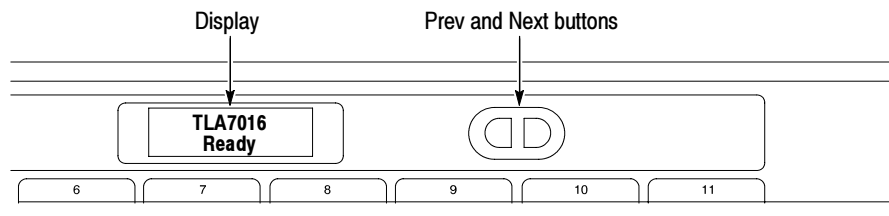

Figure 3-16: New front panel display and control buttons

You can check mainframe status information by pressing the Prev or Next buttons on the new front panel. Mainframe IP address, power supply values, and chassis temperature are some examples of the information available.

Complete the Firmware Update

Load the remaining two firmware files:

1. Click Start → All Programs → Tektronix Logic Analyzer → TLA Firmware Loader.
2. Select your instrument from the Firmware Loader - Connection dialog box and click **Connect**.

3. Click **Load** in the upper portion of the Load Firmware dialog box. The Mainframe Firmware dialog box opens. See Figure 3-17.

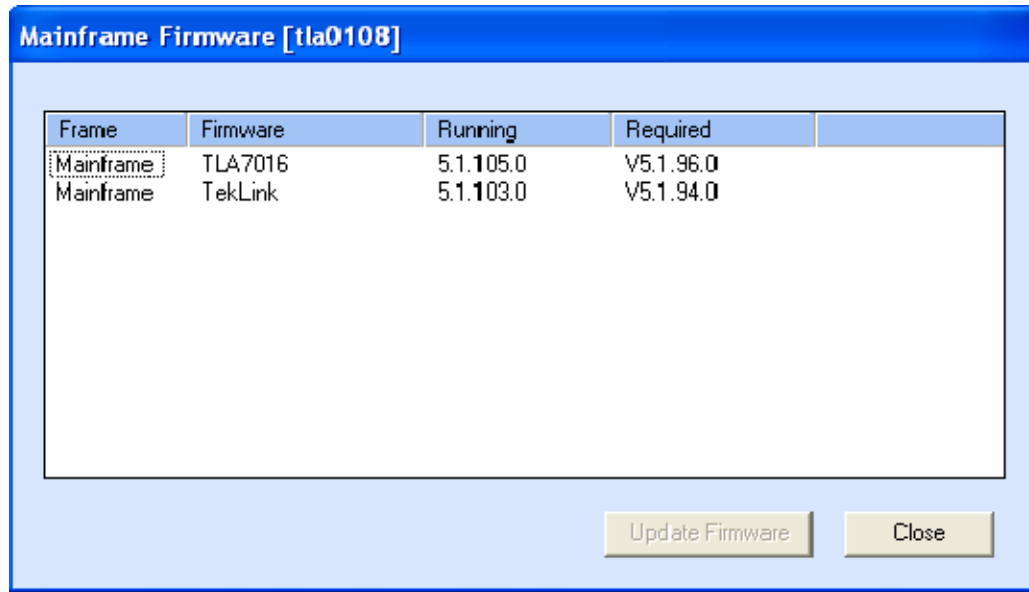

Figure 3-17: Mainframe Firmware dialog box

NOTE. You must load the firmware files in the order listed below.

4. Select the TLA7016 firmware and then click **Update Firmware**.
5. Follow the on-screen instructions.
6. When the process is done, click OK, and exit the program.
7. Power off the mainframe.
8. Power on the mainframe.
9. Repeat steps 1 through 3.
10. Select the TekLink firmware and then click **Update Firmware**.
11. Repeat steps 5 through 8 for the TekLink firmware.
12. Start the TLA Application and verify that the TLA7016 mainframe appears in the TLA Connection dialog box.

Attach the Upgrade Kit Label to the Instrument

After completing the previous steps, you need to install the upgrade kit label on the instrument to indicate that the kit is installed.

1. Select the correct instrument upgrade label from the sheet of labels, and affix it to the lower front panel of the instrument, as shown in Figure 3-18.

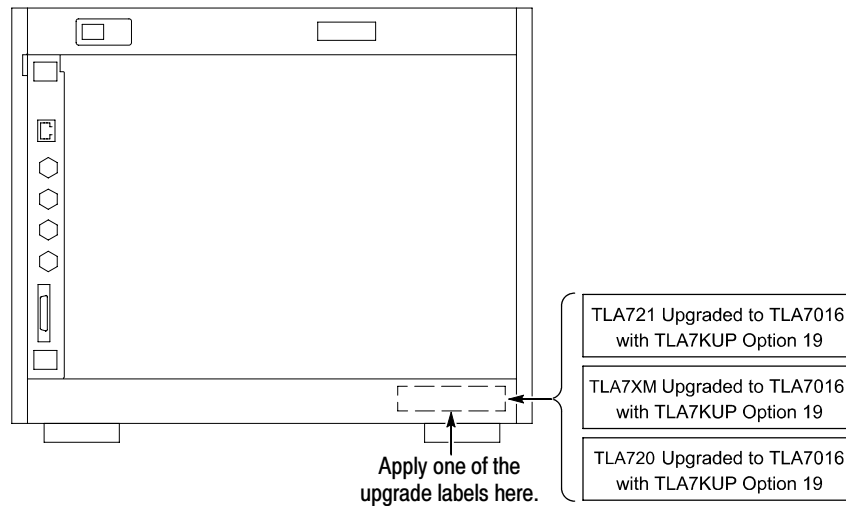

Figure 3-18: Front panel upgrade label location

Connect the Instrument Through TekLink

TekLink is a mainframe real-time communication system that coordinates trigger signals, input/output signals, and time references between mainframes.

TekLink uses a 2-meter cable (included with this kit) to connect between two TLA7000 Series logic analyzers. If you want to connect more than three benchtop mainframes together, you need a TekLink TL708EX Hub and more TekLink cables.

For more information on connecting TekLink components, refer to the *TLA7000 Series Logic Analyzer Installation Manual*.

Preset IP Addresses

You may need to change the IP address of the benchtop mainframe, depending on the requirements of the network that it will be connected to. A preset list of recommended IP addresses is programmed into the TLA7016 Interface Module. For information about entering other IP addresses, refer to the *TLA7000 Series Logic Analyzer Installation Manual*.

To cycle through the list of preset IP addresses, do the following:

1. Press and hold the recessed RESET button on the TLA7016 Interface Module. (See Figure 3-19). The front-panel display cycles every 2-3 seconds to the next preset address listed in Table 3-2.

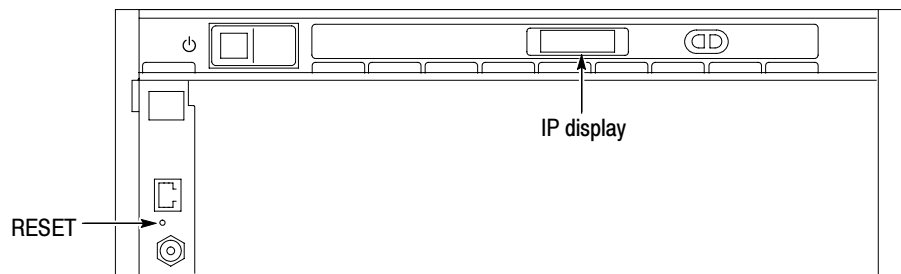

Figure 3-19: Setting the IP address

Table 3-2: Preset IP addresses

Selection	IP address	Subnet mask	Default gateway	Comments
Use: DHCP	--	--	--	IP addressing provided by DHCP-capable router
Use: 169.254.0.19	169.254.0.19	255.255.0.0	0.0.0.0	Static, non-routable address used for direct PC connection
Use: 169.254.0.20	169.254.0.20	255.255.0.0	0.0.0.0	Static, non-routable address used for direct PC connection
Use: 192.168.0.19	192.168.0.19	255.255.0.0	0.0.0.0	Static, non-routable address used for private LAN with DHCP-capable router
Use: 192.168.0.20	192.168.0.20	255.255.0.0	0.0.0.0	Static, non-routable address used for private LAN with DHCP-capable router
Factory default	--	--	--	Return to factory settings (Use DHCP and restore default Host Name to TLA7016_<Mainframe S/N>)
No change	--	--	--	Retain current IP address and Host Name

Installing the Bracket Kit

If you are using your benchtop logic analyzer outside of a rackmount environment, you can use the bracket kit to mount the TLA7PC1 controller, GbE switch, and TL708EX Hub together with your benchtop mainframe.

Left and right-side brackets and mounting screws are included in the kit. Refer to Figure 3-20 and use the following procedure.

1. Place the components you want to mount on top of the logic analyzer, putting the heaviest units lowest in the stack.
2. Align one of the brackets to the frame of the logic analyzer so that the bracket reaches all of the components, but does not extend above the top unit.
3. Fasten the bracket to the logic analyzer with one of the 8-32, P2 Pozidriv screws preinstalled on the bracket.
4. Repeat steps 2 and 3 for the bracket on the other side of the logic analyzer.
5. If necessary, relocate the instrument brackets on the components you are mounting. For example, the brackets on the TL708EX Hub come mounted to the back of the unit, with installation instructions on the bottom of the unit.
6. Using the 10-32, P2 Pozidriv screws preinstalled on the brackets, fasten the components to the brackets.

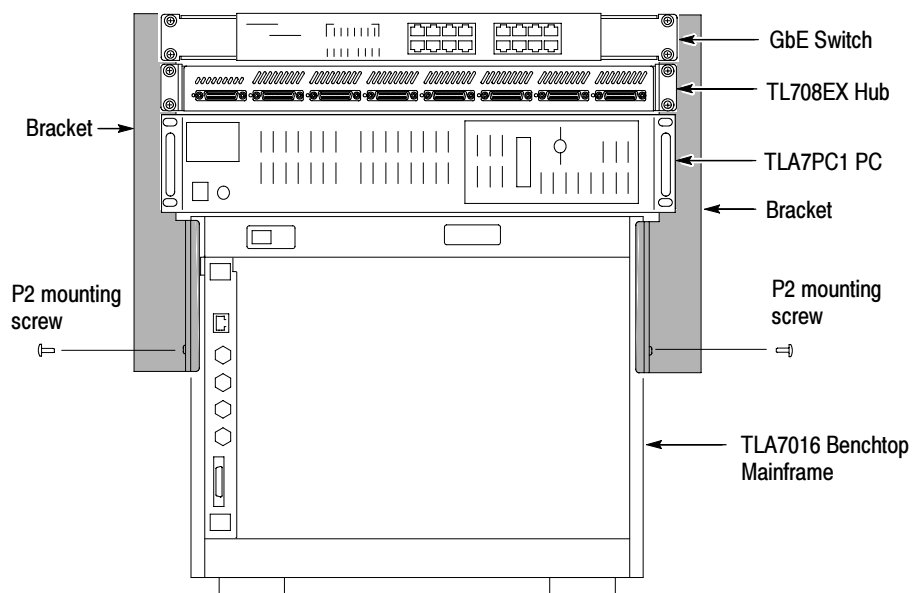

Figure 3-20: Bracket kit for the TLA7016 benchtop mainframe installed

Troubleshooting Tips

If you cannot establish a communication link between the controller and the mainframe, do the following:

1. Bring up the DOS window on the controller and enter **ipconfig**.

The address that returns should be 169.254.x.x with a subnet mask of 255.255.0.0 (the default IP address of the controller).

2. If the above address is not returned, enter **ipconfig release** and then **ipconfig renew**.

3. Enter **ping 169.254.0.19** (the factory-set IP address of the mainframe). See Figure 3-21 for an example of the expected reply from the mainframe.

```

Microsoft Windows XP [Version 5.1.2600]
(C) Copyright 1985-2001 Microsoft Corp.

C:\Documents and Settings\Administrator>ipconfig

Windows IP Configuration

Ethernet adapter Local Area Connection 2:

    Connection-specific DNS Suffix  . : 
    Autoconfiguration IP Address. . . : 169.254.171.127
    Subnet Mask . . . . . : 255.255.0.0
    Default Gateway . . . . . : 

C:\Documents and Settings\Administrator>ping 169.254.0.19

Pinging 169.254.0.19 with 32 bytes of data:
Reply from 169.254.0.19: bytes=32 time<1ms TTL=64
Reply from 169.254.0.19: bytes=32 time<1ms TTL=64
Reply from 169.254.0.19: bytes=32 time<1ms TTL=64
Reply from 169.254.0.19: bytes=32 time<1ms TTL=64

Ping statistics for 169.254.0.19:
    Packets: Sent = 4, Received = 4, Lost = 0 (0% loss),
    Approximate round trip times in milli-seconds:
        Minimum = 0ms, Maximum = 0ms, Average = 0ms

C:\Documents and Settings\Administrator>
    
```

Figure 3-21: Seeking a reply from the mainframe

4. If you get a reply using the ping command, but cannot see the mainframe in the configuration dialog box, check to see if a firewall is enabled.



TLA7KUP Option 29

TLA7KUP Option 29: Floppy Disk Drive

TLA7KUP option 29 provides parts and instructions to add an USB floppy disk drive to your TLA7012 or TLA7016 Series Logic Analyzer.

Instruments

TLA7012 Series Logic Analyzers	All Serial Numbers
TLA7016 Series Logic Analyzers	All Serial Numbers

Minimum Tool and Equipment List

No special tools or equipment are required.

Parts List

Table 4-1: TLA7KUP Option 29 parts list

Quantity	Part number	Description
1 ea	119-6960-xx	3.5 in floppy disk drive, USB
1 ea	N/A	TLA7KUP kit label

Installation Prerequisite

Requires Version 5.0 TLA Application Software or higher, Windows XP Professional operating system, and 512 MB minimum mainframe memory.

Installation Instructions

Follow the instructions that come with the floppy disk drive. Connect the floppy disk drive to one of the unused USB ports on the logic analyzer or external controller.

Attach the Upgrade Kit Label to the Instrument

After completing the previous steps, you need to install the upgrade kit label on the instrument to indicate that the kit is installed.

Locate the big label on the rear of the instrument, and then attach the TLA7KUP kit label as shown in Figure 4-1.

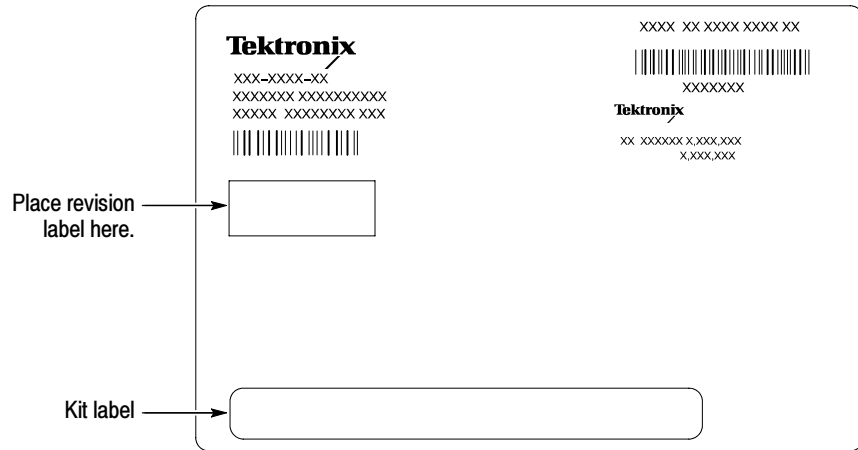

Figure 4-1: Kit label locations



TLA7KUP Option 39

TLA7KUP Option 39: USB Security Block for TLA7012 Series Logic Analyzers

TLA7KUP option 39 provides parts and instructions to add a USB Security block to your TLA7012 Logic Analyzer.

Instruments

TLA7012 Logic Analyzers All Serial Numbers

Minimum Tool and Equipment List

T-15 Torx driver

Parts List

Table 5-1: TLA7KUP Option 39 parts list

Quantity	Part number	Description
1 ea	407-5154-00	USB Security block, bracket, lock housing, main
1 ea	407-5155-00	USB Security block, bracket, lock housing, cover
2 ea	211-0721-00	Bracket screw (one spare included)
1 ea	335-1469-00	Set of USB Security block labels
1 ea	N/A	TLA7KUP Kit labels

Installation Prerequisite

None

Installation Instructions

This procedure contains three parts:

- Disconnect the USB cables from inside the front of the instrument (you must remove the front panel display assembly to gain access)
- Mount the lock assembly over the USB connectors on the rear of the instrument
- Apply labels



CAUTION. *To prevent static discharge damage, service the product only in a static-free environment. Observe standard handling precautions for static-sensitive devices while installing this kit. Always wear a grounded wrist strap, grounded foot strap, and static resistant apparel while installing this kit.*

Disable the Front-Panel USB Connections

Start the installation by doing the following steps and referring to Figure 5-1 on page 5-3.

1. Disconnect all cords, probes, and modules from the instrument.
2. Set the instrument on the bottom feet.
3. Remove the six T-15 screws from the right cover and remove the cover.

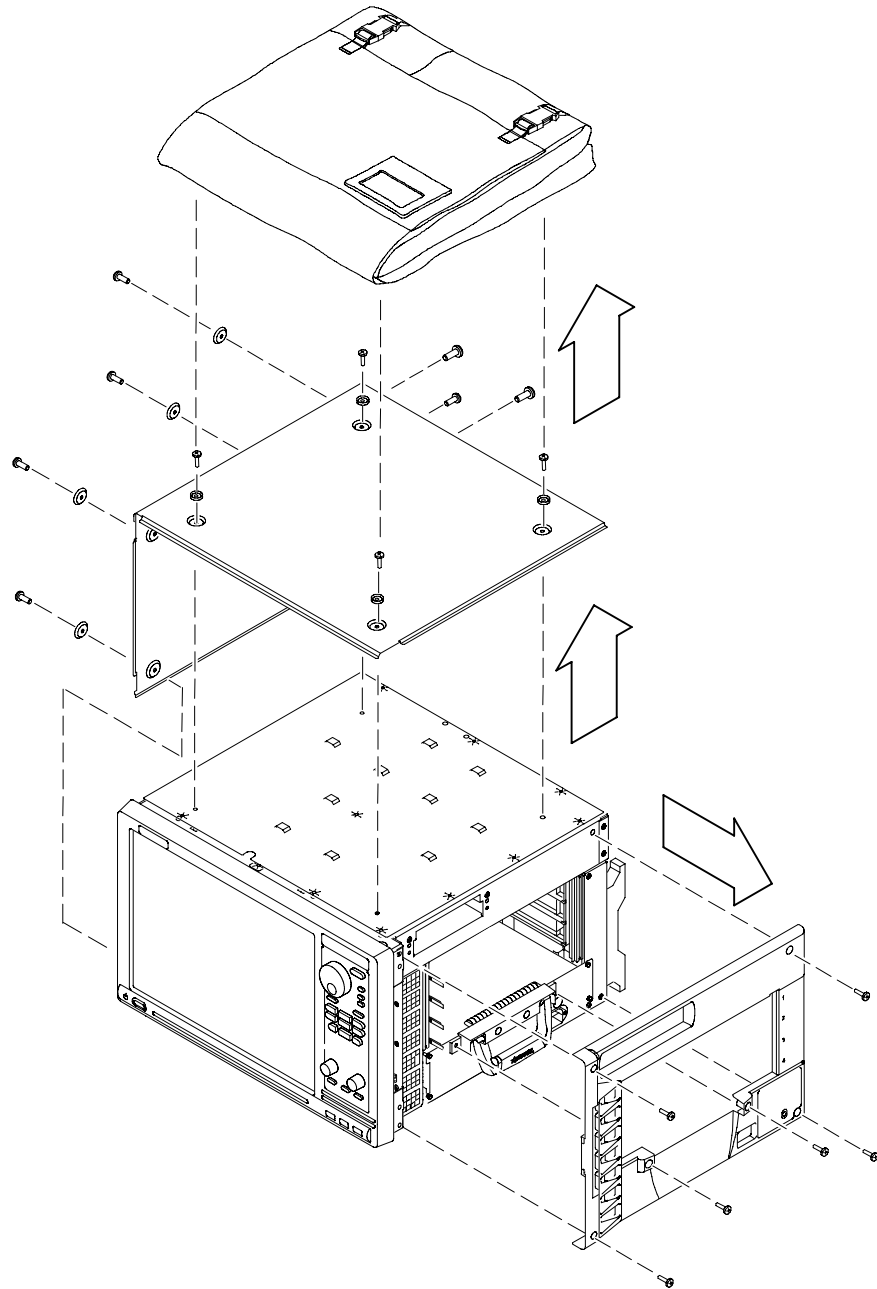

Figure 5-1: Remove the instrument enclosure

4. Remove the accessory pouch and snap studs (4 T-15 screws).
5. Remove the four skid feet from the left side (4 T-15 screws).
6. Remove the three remaining T-15 screws from the top left cover and then remove the cover.

7. Set the instrument on the rear feet.
8. Remove the 12 T-15 screws from the front panel trim. See Figure 5-2.

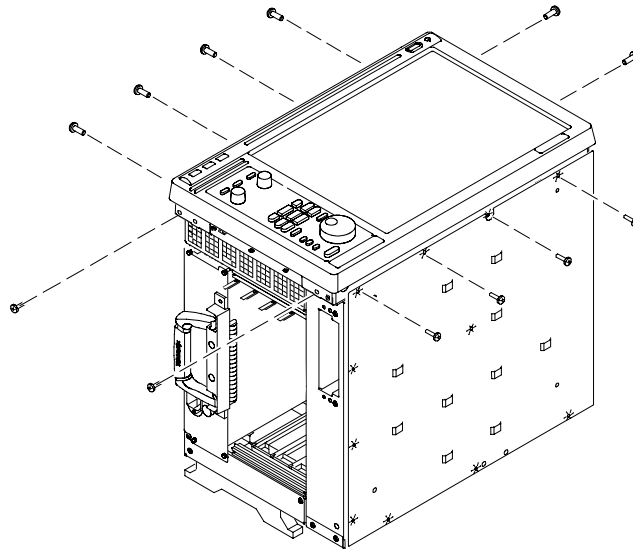

Figure 5-2: Remove the front-panel trim screws

9. Set the instrument back on the bottom feet.
10. Tilt the top of the front panel trim out about 8 inches. See Figure 5-3.

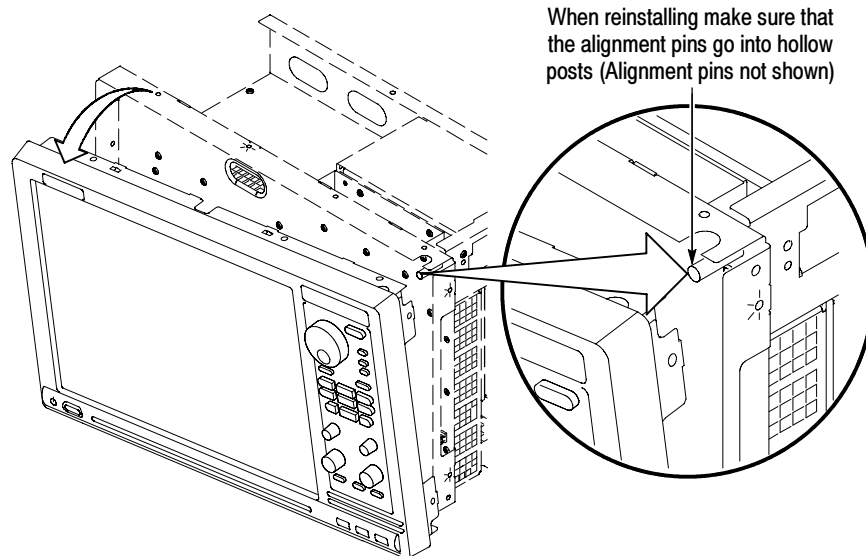

Figure 5-3: Tilt the front panel forward for cable access

11. Disconnect the three USB cables from the front panel assembly.
See Figure 5-4.

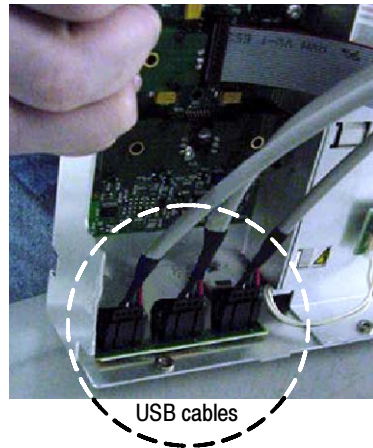

Figure 5-4: Disconnect the USB cables from the front panel

12. Reinstall the front panel assembly by following steps 1 through 11 in reverse.
To avoid damaging the USB and DVD cables, dress the cables properly just before you attach the front panel to the chassis. See Figure 5-5.



Figure 5-5: Dress the cables properly

Attach Rear-Panel USB Security Block

Continue the installation with the following procedure:

1. Set the instrument on the bottom feet with the rear panel facing you.
2. Insert the tab of the main lock housing into the slot on the instrument under the USB connectors. Fasten the lock housing to the instrument with the T-15 screw. See Figure 5-6.

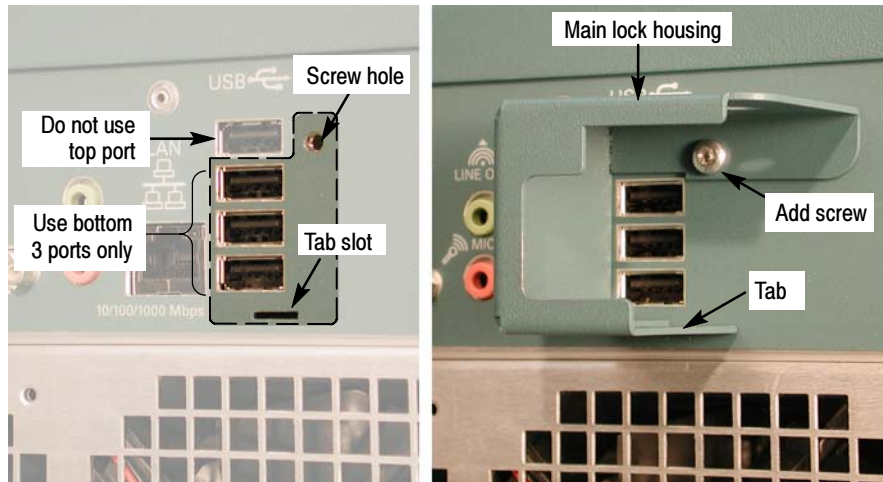

Figure 5-6: Mount the main lock housing to the instrument

3. Connect the cables. Do not use the top port. See Figure 5-7.



Figure 5-7: Connect the cables

4. Slide the lock housing cover into the main lock housing and over the cables so that the padlock holes line up. See Figure 5-8.



Figure 5-8: Slide the housing cover into place

5. Attach a padlock through the padlock holes. The holes will accommodate a 9/32-in shackle. See Figure 5-9.



Figure 5-9: Attach a padlock

Attach the Upgrade Kit Labels to the Instrument

After completing the previous steps, you need to install the upgrade kit labels on the instrument to indicate that the kit is installed.

1. Locate the big label on the rear of the instrument, and then attach the TLA7KUP kit label as shown in Figure 5-10.

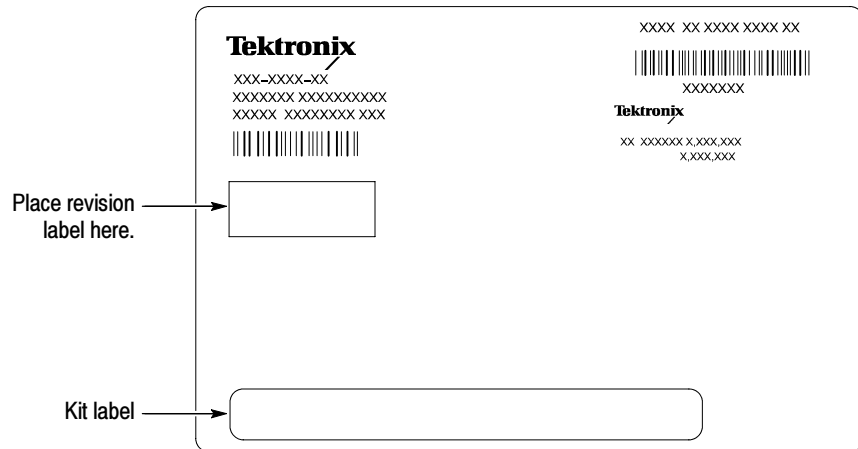

Figure 5-10: Attach the revision and kit labels

2. Attach one of the USB PORTS ARE DISABLED notification labels on the top rear of the instrument, as shown in Figure 5-11.

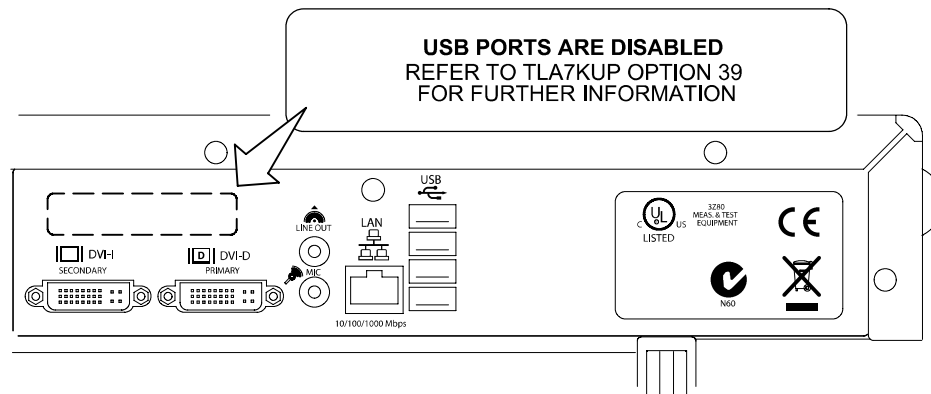

Figure 5-11: Attach the notification label to the rear of the instrument

3. Attach another USB PORTS ARE DISABLED notification label on the front of the instrument, over the USB connectors, as shown in Figure 5-12.

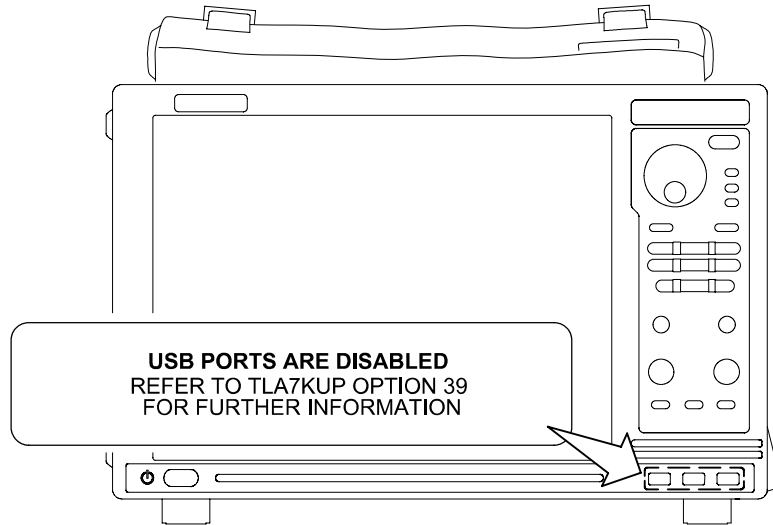

Figure 5-12: Attach the notification label over the front-panel USB connectors



TLA7KUP Option 41

TLA7KUP Option 41: TLA Application Software and Windows Operating System Upgrade

TLA7KUP option 41 supports the upgrade to TLA application software version 5.1 and Microsoft Windows XP Professional operating system.

Use this kit to upgrade TLA7000 series logic analyzers using restore media. This process overwrites the entire contents of your hard disk drive.

NOTE. *Several third-party software applications are included to use with your logic analyzer. These applications may include software license agreements. Be sure to abide by those license agreements.*

Instruments

TLA7000 Series Logic Analyzers

All Serial Numbers

Minimum Tool and Equipment List

No special tools or equipment are required to install this option.

Parts List

Table 6-1: TLA7KUP Option 41 parts list

Quantity	Part number	Description
1 ea	N/A	Tektronix Logic Analyzer Family Application Software Version 5.1
1 ea	N/A	TLA7012 Restore Media, DVD-ROM, SLP, TLA Application Software Version 5.1
1 ea	N/A	TLA7PC1 Restore Media, DVD-ROM, SLP, TLA Application Software Version 5.1
1 ea	N/A	Microsoft Windows XP Professional Certificate of Authenticity
1 ea	N/A	Nero OEM Suite 3 CD
1 ea	016-1524-xx	TLA mouse pad
5 ea	131-4356-xx	Jumper with pull-tab
1 sheet	N/A	Software revision labels
1 ea	N/A	TLA7KUP kit label
1 ea	N/A	Easy Restore license

TLA7KUP Option 41: Application Software and Windows Operating System Instructions

These instructions guide you through the process of upgrading your TLA7000 series logic analyzer software and firmware.



CAUTION. *The software installation procedure overwrites the entire contents of your hard disk. To save any files or software applications on the hard disk, back them up to another media before continuing with this procedure.*

Install Software

This kit includes media that contain the Microsoft Windows XP Professional operating system and the latest application software. All software required to run the logic analyzer comes with the media, with the exception of any microprocessor support packages or non-logic analyzer application software.

Back Up Files

Before loading the restore media, back up any files, applications, and personal files. Use the Windows Search utility to locate the files to back up. Table 6-2 lists examples of file suffixes that you may want to back up.

Table 6-2: TLA user file suffixes

Suffix	Description
.tla	TLA setup files and stored data
.tsf	TLA symbol files
.tbf	Tektronix binary format
.tls	TLA script file
.tpg	Tektronix pattern generator files
.txt	Tektronix TLA data exchange format files
.stk	Stack files
.spz	Protocol files

Install Windows XP Professional and the TLA Application Software

This procedure automatically reformats the hard disk, installs the Windows XP Professional Operating system software, and installs the the Tektronix Logic Analyzer application software. This process may take several minutes.

Change the BIOS Boot Settings and Load the Restore Media. Before installing the restore media, you may need to change the BIOS settings to enable booting from the DVD drive.

1. Restart the logic analyzer and then press function key F2 to enter the BIOS setup.
2. In the BIOS setup, go to the Boot menu.
3. Select Boot Device Priority.
4. Set the Boot devices to boot from the CD first.
5. Insert the first CD in the CD-ROM drive.
6. Save the settings by pressing function key F10 and confirm that you want to save the new settings. The instrument will reboot and begin the installation procedure.
7. Review the license agreement. If you agree to the terms of the license agreement, proceed with the next step.
8. Follow the on-screen instructions to complete the installation procedure.

If EasyRestore detects errors and prompts you to allow the program to fix them, click Yes to continue the upgrade process.

9. Reinstall any user files that you backed up previously. Reinstall any software (such as the microprocessor support packages) that you want to use on the logic analyzer.

Upgrade the Instrument Firmware

Complete the following steps if the TLA startup messages indicate that you need to upgrade the instrument firmware (Refer to *Update the TLA Module Firmware* on page 6-5 to upgrade module firmware):

1. Log on as Administrator.
2. Exit the logic analyzer application.
3. Click Start → All Programs → Tektronix Logic Analyzer → TLA Firmware Loader.
4. Select your instrument from the Firmware Loader - Connection dialog box and click **Connect**.

5. To identify or load new mainframe firmware, click **Load** in the upper portion of the Load Firmware dialog box.
6. Select the firmware that you want to load and then click **Update Firmware** (in most cases you will use the default selection in the dialog box).
7. Follow the on-screen instructions.

Update TLA Module Firmware

Complete the following steps if the TLA startup messages indicate that you need to upgrade module firmware. You can update multiple modules and module types during a single firmware update session.

NOTE. *If you accidentally closed the startup messages indicating which modules need firmware upgrades, restart the TLA application.*

1. Log on as Administrator.
2. Note the modules that require new firmware.
 - a. For TLA7Axx/TLA7NAx series logic analyzer modules skip steps 3–9 and go directly to step 10 on page 6-5.
 - b. For all other module types continue with step 3.
3. Turn off the instrument.
4. Remove the module requiring the upgrade from the instrument.
5. Refer to Figure 6-1 and locate the flash programming pins on the rear of the module.
6. Install a jumper on the flash programming pins (use one of the spare jumpers that came with your logic analyzer).
7. Reinstall the module(s) in the instrument.
8. Power on the instrument.

NOTE. *Any modules with the flash programming jumper installed will not display in the TLA or Pattern Generator System window.*

9. Log on as Administrator and then wait for the TLA application to start.
10. Exit the logic analyzer application.

11. Click Start → All Programs → Tektronix Logic Analyzer → TLA Firmware Loader.
12. Select your instrument from the Firmware Loader - Connection dialog box and click **Connect**.
13. Click **Load** in the lower portion of the Firmware Loader dialog box.
14. Select the modules that you want to update from the list of modules displayed in the Supported list box near the top of the menu. If you are updating more than one module at a time, note the slot location of the module in the selection box.
15. Select **Load Firmware** from the Execute menu.

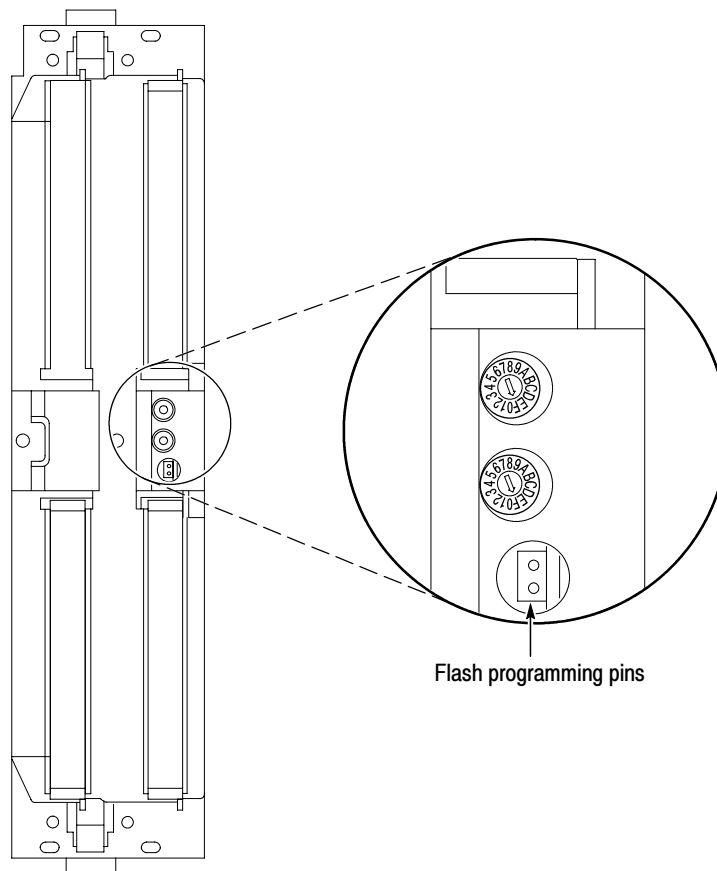

Figure 6-1: Flash programming pins

16. Click the proper .lod file for the selected module; refer to Table 6-3 on page 6-7, if necessary.

NOTE. Be sure to select the proper .lod file for each module. Note the slot number in the title bar so that you select the correct module for the .lod file.

Table 6-3: TLA firmware files

Module type	.lod file
TLA7NAX logic analyzer modules	TLA7NAX.lod
TLA7Axx logic analyzer modules	TLA7AXX.lod
TLA7Nx, TLA7Px, TLA7Qx logic analyzer modules	TLA7NPQ.lod
TLA7Lx and TLA7Mx logic analyzer modules	TLA7LM.lod
TLA7Dx and TLA7Ex DSO modules	FirmwareDSO.lod
TLA7PG2 Pattern Generator modules ¹	tla7pg2.lod

¹ **The .lod files for the pattern generator modules are located in the C:\Program Files\Tektronix Pattern Generator\Firmware folder. All other files are located in the C:\Program files\TLA 700\Firmware folder.**

17. Click **Open**. When prompted to confirm your action; click **Yes**.

NOTE. The program will not allow you to load firmware to an incompatible module. For example, the program will not load DSO firmware to a logic analyzer module.

The program will load the firmware for each module one at a time. The process may take several minutes per module.

18. When the upgrade is complete, exit the firmware loader program.
19. Turn off the instrument and disconnect the power cord.
20. Remove the module from the instrument.
21. For all modules except the TLA7Axx or TLA7NAX modules, remove the jumper from the Flash programming pins on the rear of the module. Keep the jumper for future updates.
22. Locate the big label on the side of the module.
23. Attach a new revision label and kit label on the big label for each module as shown in Figure 6-2 on page 6-8.
24. Locate the big label on the either the portable mainframe or on the side of the Benchtop controller (depending on your instrument) and attach the revision label and the TLA7KUP kit label as shown in Figure 6-2 on page 6-8.

NOTE. If there already is an upgrade kit label installed, install the new label just above or below the old one. However, ensure that you install the software revision label over the old revision label to indicate the current version of software on your instrument.

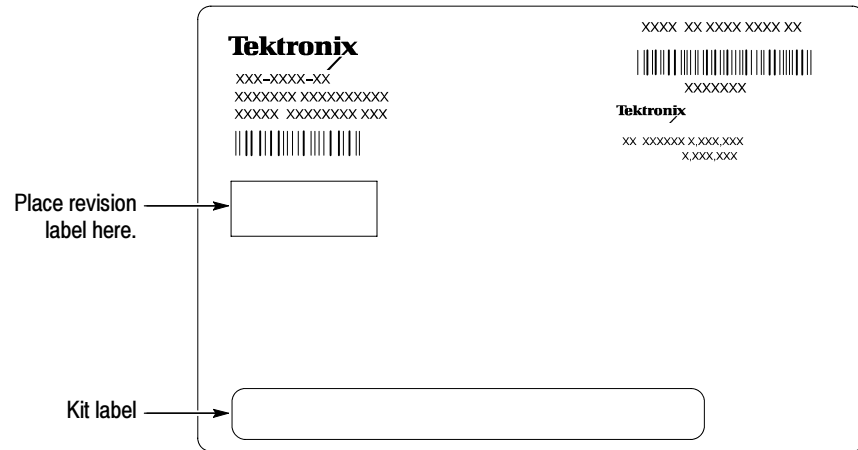

Figure 6-2: Revision and kit label locations

25. Reinstall the module in the instrument, tighten the hold-down screws, and then reconnect the probes.
26. Reconnect the power cord and power on the instrument.
27. Verify that the power-on diagnostics pass.

Calibrate the Instrument

After verifying proper operation, you need to calibrate the logic analyzer.

1. Allow the instrument to warm up for at least 30 minutes before continuing.
2. In the System window, select Calibration and Diagnostics from the System menu.
3. Click the Self Calibration tab.
4. Select the Run button and click Yes to any confirmation messages.

NOTE. The calibration process may take several minutes.

The Status column indicates Running while the instrument is being calibrated.

5. Verify that the Status column changes to Calibrated.
6. Close the dialog box.

Installing the TLA Application Software on a PC

You can install the TLA application software on a PC for the following purposes:

- Run the TLA application software in the Offline mode (similar to TLAVu in earlier software versions).
- Control a logic analyzer with the same TLA Application Software over a network.

Install Third-Party Software

To use all of the features of the TLA application software on your PC, you must install additional third-party software. The following third-party software is available on the TLA Application Software CD V5.1, or higher:

- The NI-GPIB software allows you to use the iView software with your PC.
- The SnagIt software is useful for copying screen shots of logic analyzer data for use with other applications.

NOTE. *Several third-party software applications are included to use with your logic analyzer. These applications may include software license agreements. Be sure to abide by those license agreements.*

Install the NI-GPIB Software. Complete the following steps to install the third-party software on your PC:

1. Install the first TLA Application Software CD in the CD drive.
2. Browse to the NI-GPIB-USB folder on the CD and run the Setup.exe program.
3. Follow the on-screen instructions and note the items below:
 - a. When prompted, select the Typical installation option.
 - b. When the Add GPIB wizard appears, select **GPIB-USB-B**.
 - c. After restarting the instrument, the NI-488.2 Getting Started wizard displays. This is not needed; select **Do not show at Windows startup**.

- d. When you first connect the iView cable, the instrument will detect the new hardware. Select **Install the software automatically (Recommended)**.

Install the Snagit Software. Complete the following steps to install the Snagit software on your PC:

1. Browse to the Snagit folder on the CD and run the Setup.exe program.
2. Follow the on-screen instructions.

Install the TLA Application Software

Browse to the TLA Application software folder on the CD and run the Setup.exe program. Follow the on-screen instructions to install the TLA application software.

If you have an older version of the software on the hard disk, the installation program will detect it and ask if you want to remove it. Follow the on-screen instructions to remove the software, answering “Yes” to any prompts. Restart the instrument when prompted and run the Setup.exe program again.

Start the TLA Application

If you have installed the TLA application software on a PC for remote operation, start the software by double-clicking on the TLA Application icon. The TLA Connection dialog box displays.

1. Select an instrument in the TLA Connection dialog box and then click **Connect**. If your instrument is connected to a network, you can connect to any unused instrument on your local network.
2. Click **Offline** to start an offline version of the TLA application software. The TLA Offline software allows you to run the TLA application without connecting to an instrument. You can analyze previously acquired data from a logic analyzer, create or modify reference memories, or perform system tests without being connected to an instrument.

Attach the Upgrade Kit Label to the Instrument

After completing the previous steps, you need to install the upgrade kit label on the instrument to indicate that the kit is installed.

Locate the big label on the rear of the instrument and then attach the software revision label and the TLA7KUP kit label as shown in Figure 6-3.

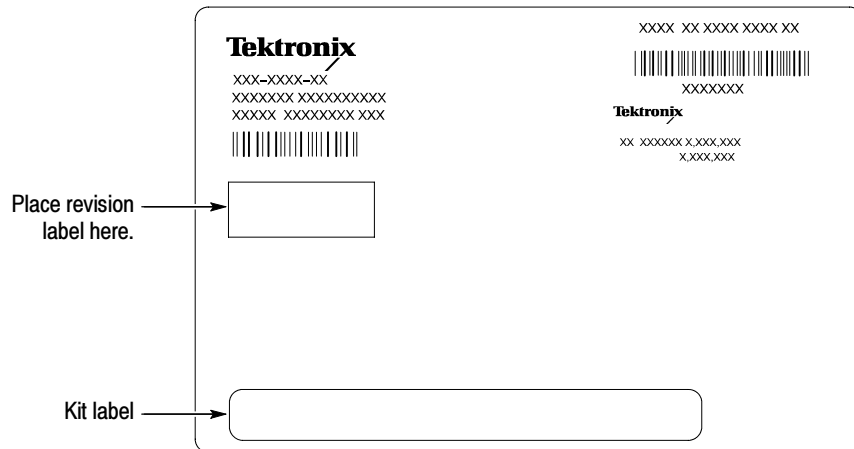

Figure 6-3: Revision and kit label locations



TLA7KUP Option 42

TLA7KUP Option 42: TLA Application Software Upgrade

TLA7KUP Option 42 supports the upgrade to TLA application software version 5.1. This kit provides instructions to upgrade the TLA application software and firmware for a TLA7000 Series logic analyzer with TLA application software version 5.0 or higher. This software will run only on instruments with the Microsoft Windows XP Professional operating system purchased from Tektronix. The software will also run on a PC with Windows XP Professional or Windows 2000 Professional operating systems.

Instruments

TLA7000 Series Logic Analyzers

All serial numbers

Installation Prerequisite

Requires TLA Application Software Version 5.0 (or higher), Microsoft Windows XP Professional operating system.

Parts List

Table 7-1: TLA7KUP Option 42 parts list

Quantity	Part number	Description
1 ea	N/A	Tektronix Logic Analyzer Family Application Software Version 5.1
1 ea	N/A	Nero OEM Suite 3 CD
1 ea	016-1524-xx	TLA mouse pad
1 sheet	N/A	Software revision labels
5 ea	131-4356-xx	Jumper with pull-tab
1 ea	N/A	TLA7KUP kit label

Minimum Tool and Equipment List

No special tools or equipment are required to install this option.

TLA7KUP Option 42: Application Software Instructions

The following instructions direct you through the process of upgrading the TLA application software on your TLA7000 series logic analyzer.

NOTE. *Third-party software applications are included to use with your logic analyzer. These applications may include software license agreements. Be sure to abide by those license agreements.*

Upgrade Instruction Overview

While performing the upgrade procedures, keep the following items in mind:

- Throughout this procedure you will see the term “log on as Administrator.” The instrument is set up to automatically log on as Administrator (with no password) so you may not see the log on prompt. If the network setups have been changed on your instrument, make sure that you log on as Administrator or as a user who has administrator privileges. Failure to do so can prevent the software upgrade from completing successfully.
- After logging on as administrator, quit any applications.
- If your instrument does not display the file extensions, you need to change your folder options to display the file extensions. (From the Control Panel, double-click Folder Options, select the View tab, and then deselect the “Hide file extensions for known file types” selection.)
- Use the Windows Add or Remove Programs Control Panel utility to remove existing software.
- You may be asked to restart Windows after you install each software package. If you do not restart Windows when prompted, your software may not install properly and can cause unpredictable behavior.
- If Windows does not restart normally, press and hold the On/Standby button for five or six seconds to force a shutdown.

Update the Software

NOTE. You may want to compare the software version listed under Software Compatibility in the release notes against the software on your instrument. If the software versions do not match, remove the old software using the Windows Add or Remove Programs utility and then install the new software from the TLA Application CD.

The TLA Application software uses a wizard to remove older software and install the new software for your instrument.

1. Log on as Administrator.
2. Insert the first CD of the TLA Application software V5.1 in the instrument.
3. Start Windows Explorer, and browse to and execute D:\TLA Application SW\Setup.exe.
4. Click **Yes** to start the installation.
5. Follow any on-screen instructions. If you are asked for permission to overwrite any read-only files, select **Yes to All**.
6. After the software has been successfully installed, restart Windows.

Upgrade the Instrument Firmware

Complete the following steps if the TLA startup messages indicate that you need to upgrade the instrument firmware (Refer to *Update the TLA Module Firmware* on page 7-5 to upgrade module firmware):

1. Log on as Administrator.
2. Exit the logic analyzer application.
3. Click Start → All Programs → Tektronix Logic Analyzer → TLA Firmware Loader.
4. Select your instrument from the Firmware Loader - Connection dialog box and click **Connect**.
5. To identify or load new mainframe firmware, click **Load** in the upper portion of the Load Firmware dialog box.
6. Select the firmware that you want to load and then click **Update Firmware** (in most cases you will use the default selection in the dialog box).
7. Follow the on-screen instructions.

Update TLA Module Firmware

Complete the following steps if the TLA startup messages indicate that you need to upgrade module firmware. You can update multiple modules and module types during a single firmware update session.

NOTE. *If you accidentally closed the startup messages indicating which modules need firmware upgrades, restart the TLA application.*

1. Log on as Administrator.
2. Note the modules that require new firmware.
 - a. For TLA7Axx/TLA7Nxx series logic analyzer modules skip steps 3–9 and go directly to step 10 on page 7-5.
 - b. For all other module types continue with step 3.
3. Turn off the instrument and disconnect the power cord.
4. Remove the module requiring the upgrade from the instrument.
5. Refer to Figure 7-1 and locate the flash programming pins on the rear of the module.
6. Install a jumper on the flash programming pins (use one of the spare jumpers that came with your logic analyzer).
7. Reinstall the module(s) in the instrument.
8. Reconnect the power cord and then power on the logic analyzer.

NOTE. *Any modules with the flash programming jumper installed will not display in the TLA or Pattern Generator System window.*

9. Log on as Administrator and then wait for the TLA application to start.
10. Exit the logic analyzer application.
11. Click Start → All Programs → Tektronix Logic Analyzer → TLA Firmware Loader.
12. Select your instrument from the Firmware Loader - Connection dialog box and click **Connect**.
13. Click **Load** in the lower portion of the Firmware Loader dialog box.

14. Select the modules that you want to update from the list of modules displayed in the Supported list box near the top of the menu. If you are updating more than one module at a time, note the slot location of the module in the selection box.
15. Select **Load Firmware** from the Execute menu.

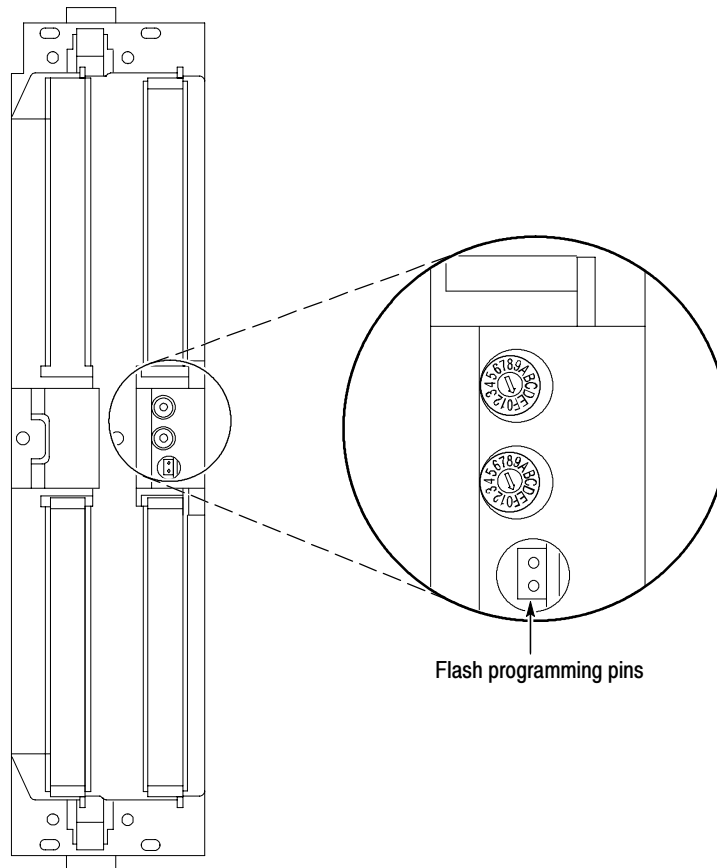

Figure 7-1: Flash programming pins

16. Click the proper .lod file for the selected module; refer to Table 7-2 on page 7-7, if necessary.

NOTE. Be sure to select the proper .lod file for each module. Note the slot number in the title bar so that you select the correct module for the .lod file.

Table 7-2: TLA firmware files

Module type	.lod file
TLA7NAX logic analyzer modules	TLA7NAX.lod
TLA7Axx logic analyzer modules	TLA7AXX.lod
TLA7Nx, TLA7Px, TLA7Qx logic analyzer modules	TLA7NPQ.lod
TLA7Lx and TLA7Mx logic analyzer modules	TLA7LM.lod
TLA7Dx and TLA7Ex DSO modules	FirmwareDSO.lod
TLA7PG2 Pattern Generator modules ¹	tla7pg2.lod

¹ **The .lod files for the pattern generator modules are located in the C:\Program Files\Tektronix Pattern Generator\Firmware folder. All other files are located in the C:\Program files\TLA 700\Firmware folder.**

17. Click **Open**. When prompted to confirm your action; click **Yes**.

NOTE. *The program will not allow you to load firmware to an incompatible module. For example, the program will not load DSO firmware to a logic analyzer module.*

The program will load the firmware for each module one at a time. The process may take several minutes per module.

18. When the upgrade is complete, exit the firmware loader program.
19. Turn off the instrument and disconnect the power cord.
20. Remove the module from the instrument.
21. For all modules except the TLA7Axx or TLA7NAX modules, remove the jumper from the Flash programming pins on the rear of the module. Keep the jumper for future updates.
22. Locate the big label on the side of the module.
23. Attach a new revision label and kit label on the big label for each module as shown in Figure 7-2 on page 7-8.
24. Locate the big label on the either the portable mainframe or on the side of the Benchtop controller (depending on your instrument) and attach the revision label and the TLA7KUP kit label as shown in Figure 7-2 on page 7-8.

NOTE. If there already is an upgrade kit label installed, install the new label just above or below the old one. However, ensure that you install the software revision label over the old revision label to indicate the current version of software on your instrument.

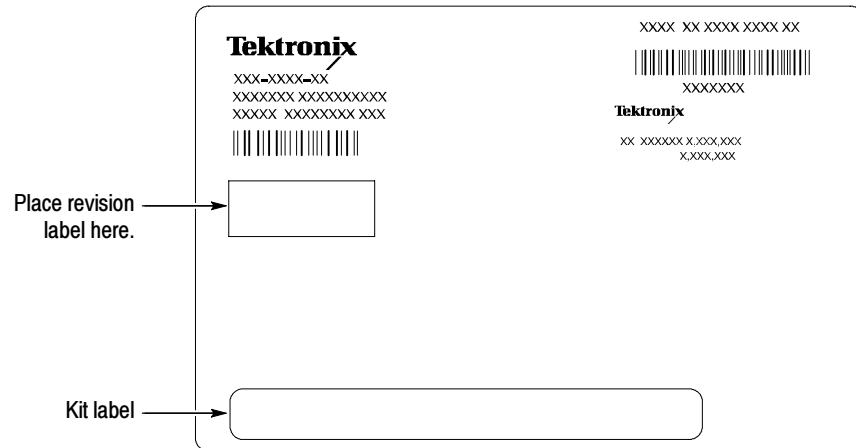

Figure 7-2: Revision and kit label locations

25. Reinstall the module in the instrument, tighten the hold-down screws, and then reconnect the probes.
26. Reconnect the power cord and power on the instrument.
27. Verify that the power-on diagnostics pass.

Calibrate the Instrument

After verifying proper operation, you need to calibrate the logic analyzer.

1. Allow the instrument to warm up for at least 30 minutes before continuing.
2. In the System window, select Calibration and Diagnostics from the System menu.
3. Click the Self Calibration tab.
4. Select the Run button and click Yes to any confirmation messages.

NOTE. The calibration process may take several minutes.

The Status column indicates Running while the instrument is being calibrated.

5. Verify that the Status column changes to Calibrated.
6. Close the dialog box.

Installing the TLA Application Software on a PC

You can install the TLA application software on a PC for the following purposes:

- To run the TLA application software in the Offline mode (similar to TLAVu in earlier software versions).
- To control a logic analyzer with the same TLA application software version over a network.

Install Third-Party Software

To use all of the features of the TLA application software on your PC, you must install additional third-party software. The following third-party software is available on the TLA Application Software CD V5.1, or higher:

- The NI-GPIB software allows you to use the iView software with your PC.
- The SnagIt software is useful for copying screen shots of logic analyzer data for use with other applications.

NOTE. *Several third-party software applications are included to use with your logic analyzer. These applications may include software license agreements. Be sure to abide by those license agreements.*

Install the NI-GPIB Software. Complete the following steps to install the third-party software on your PC:

1. Install the TLA Application Software CD in the CD drive.
2. Browse to the NI-GPIB-USB folder on the CD and run the Setup.exe program.
3. Follow the on-screen instructions and note the items below:
 - a. When prompted, select the Typical installation option.
 - b. When the Add GPIB wizard appears, select **GPIB-USB-B**.
 - c. After restarting the instrument, the NI-488.2 Getting Started wizard displays. This is not needed; select **Do not show at Windows startup**.

- d. When you first connect the iView cable, the instrument will detect the new hardware. Select **Install the software automatically (Recommended)**.

Install the Snagit Software. Complete the following steps to install the Snagit software on your PC:

1. Browse to the Snagit folder on the CD and run the Setup.exe program.
2. Follow the on-screen instructions.

Install the TLA Application Software

Browse to the TLA Application software folder on the CD and run the Setup.exe program. Follow the on-screen instructions to install the TLA application software.

If you have an older version of the software on the hard disk, the installation program will detect it and ask if you want to remove it. Follow the on-screen instructions to remove the software, answering “Yes” to any prompts. Restart the instrument when prompted and run the Setup.exe program again.

Start the TLA Application

If you have installed the TLA application software on a PC for remote operation, start the software by double-clicking on the TLA Application icon. The TLA Connection dialog box displays.

1. Select an instrument in the TLA Connection dialog box and then click **Connect**. If your instrument is connected to a network, you can connect to any unused instrument on your local network.
2. Click **Offline** to start an offline version of the TLA application software. The TLA Offline software allows you to run the TLA application without connecting to an instrument. You can analyze previously acquired data from a logic analyzer, create or modify reference memories, or perform system tests without being connected to an instrument.

Attach the Upgrade Kit Label to the Instrument

After completing the previous steps, you need to install the upgrade kit label on the instrument to indicate that the kit is installed.

Locate the big label on the rear of the instrument, and then attach the software revision label and the TLA7KUP kit label as shown in Figure 7-3.

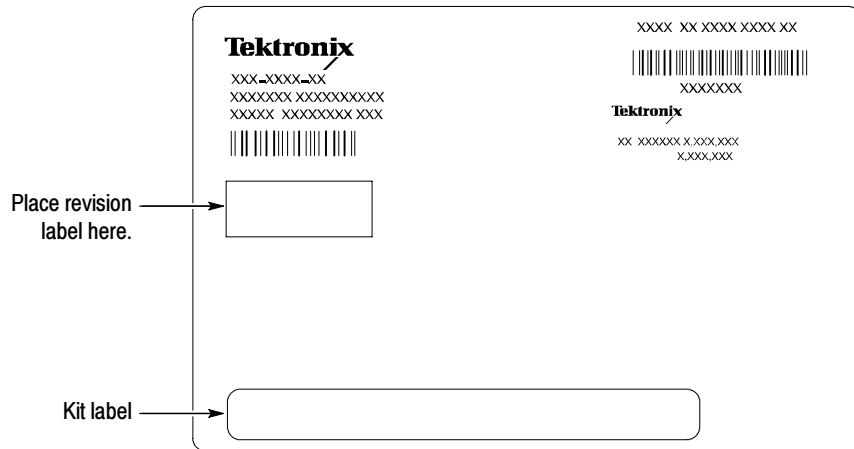

Figure 7-3: Revision and kit label locations



TLA7KUP Option IF

TLA7KUP Option IF: Upgrade Installation Service

TLA7KUP option IF provides installation of product upgrades performed at a Tektronix service location.

NOTE. *Availability of installation and on-site services depend on the type of product and may vary by geography.*

Instruments

TLA7012	All Serial Numbers
TLA7016	All Serial Numbers



TLA7KUP Option IN

TLA7KUP Option IN: On-Site Installation Service

TLA7KUP option IN provides initial product installation/configuration and start up training session including front panel and product familiarization at your site (excludes network integration).

NOTE. *Availability of installation and on-site services depend on the type of product and may vary by geography.*

Instruments

TLA7012	All Serial Numbers
TLA7016	All Serial Numbers
TLA7PC1	All Serial Numbers

